

# INSTRUCTION MANUAL

# AS/AT type

## Work Gripper



### DANGER

- This instruction manual is for production engineers and maintenance personnel in charge of operation of this product. When a beginner uses this product, receive instructions from experienced personnel, the distributor or our company.
- Before installing, operating or maintaining this equipment, carefully read this manual and the safety labels attached to the equipment. Failure to follow these instructions and safety precautions could result in serious injury, death, or property damage.
- Store this manual near equipment for future reference.
- If any questions related to safety arise about this manual, please confirm them with the distributor or our company.

## Kitagawa Corporation

77-1, Motomachi, Fuchu-shi, Hiroshima, 726-8610, Japan

Tel. +81-847-40-0561

Fax. +81-847-45-8911

# Preface

This manual provides detailed information about how to safely and correctly use the work gripper (AS, AT type).

Before starting to use this work gripper, read this manual carefully and always follow the instructions and warnings in "**Important Safety Precautions**" and "**Precautions for Use**" at beginning of the manual. Failure to follow these precautions could result in a serious accident.

## Terms and Symbols Used for Safety Messages

In this manual, precautions for handling that are considered especially important are classified and displayed as shown below depending on the damage of risk including the seriousness of the harm that could result. Please sufficiently understand the meanings of these terms and follow the instructions for safe operation.

### **Safety Alert Symbol**

The triangle is the safety alert symbol used to alert you to potential safety hazards that could result in injury or death.



Indicates a hazardous situation which, if you not avoided, will result in death or serious injury.



Indicates a hazardous situation which, if you not avoided, could result in death or serious injury.



Indicates a hazardous situation which, if you not avoided, could result in minor or moderate injury.



Indicates instructions which, if not avoided, could result in damage to the equipment or a shortened work life.

## Liability and How to Use this Manual

This product is suitable for gripping a workpiece on the rotary tables or machining centers. This product is equipped with the jaws to clamp the workpiece and they operate by means of a built-in cylinder. For any other applications, please contact us.

Our company will not assume responsibility for injury, death, damage, or loss resulting from not following the instructions in this manual.

There are countless things that cannot or should not be done, and it is impossible to cover all of them in this manual.

Therefore, do not perform any actions unless they are specifically allowed in this manual. If any questions related to safety arise about operation, control, inspection and maintenance which are not specified in this manual, please confirm them with our company or distributor before performing them.

## Guarantee and Limitation of Liability

The guarantee period of this product is 1 year after delivery.

Use the parts delivered by Kitagawa Corporation for all the parts including consumable parts. We will not assume responsibility for injury, death, damage, or loss caused by usage of parts not manufactured by Kitagawa Corporation. Additionally, if parts other than genuine parts manufactured by Kitagawa Corporation are used, this guarantee will be completely invalid.

---

# Table of Contents

---

1. Structural Drawing and Parts List .....	3
1-1. Type display	
1-2. Structural drawing	
1-3. Scope of product	
1-4. Parts list	
2.  Important Safety Precautions .....	8
3. Specifications .....	12
3-1. Specifications	
3-2. Relationship between air pressure and gripping force	
3-3. Relationship between gripping part center height, gripping force and air pressure	
4. Forming Soft Jaw .....	16
4-1. Attachment of soft jaw	
4-2. Forming soft jaw with outside diameter gripping	
4-3. Forming soft jaw with inside diameter gripping	
4-4. Forming method when you use forming jig	
5. Usage .....	20
5-1. Precautions during gripping work with work gripper	
5-2. Precautions during gripping work in irregular shape	
5-3. Precautions related to usage of jaw	
5-4. Precautions related to processing	
5-5. Attachment of locator and jig	
5-6. Precautions related to usage of lock valve unit	
6. Maintenance and Inspection .....	23
6-1. Periodic Inspection	
6-2. Grease lubrication	
6-3. Disassembling	
6-4. Inspection of lock valve unit	
7. Malfunction and Countermeasures .....	26
7-1. In the case of malfunction	
7-2. Where to contact in the case of malfunction	
<b>For Machine Tool Manufacturers (Chapter 8)</b>	
8. Attachment .....	27
8-1. Outline drawing of attachment	
8-2. Attachment of lock valve unit	
8-3. Attachment and piping of work gripper	
8-4. Attachment and piping of multi plate	
9. Trial Operation .....	30
10. Other Information .....	31
10-1. About standards and orders	
10-2. Information about markings of product	
10-3. About disposal	

# 1 . Structural Drawing and Parts List

## 1-1 Type display

Type display as shown below.

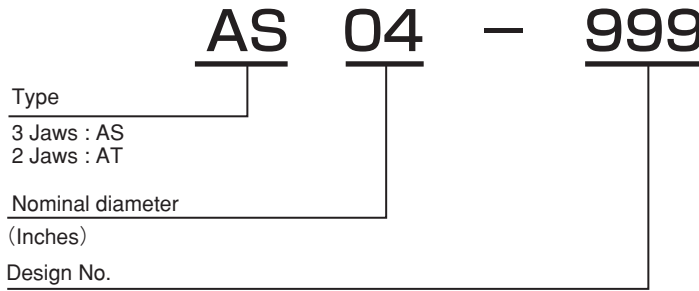

Fig. 1-1

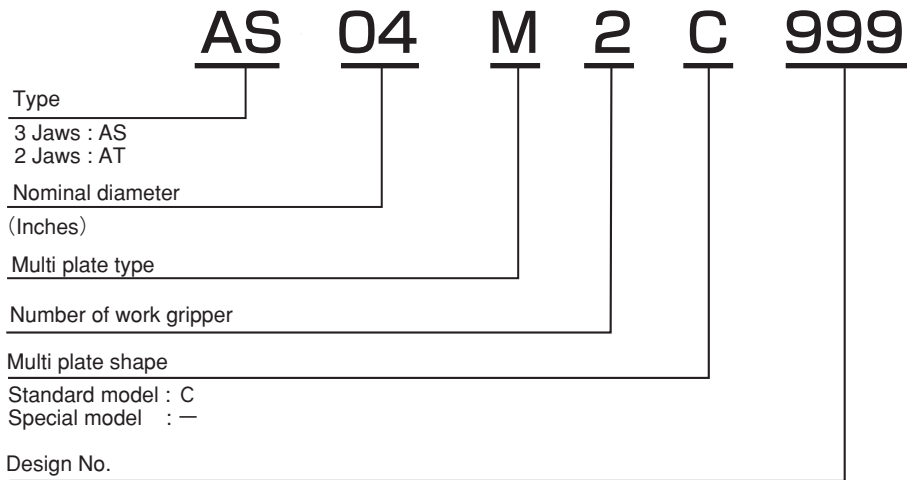

Fig. 1-2 Multi plate type

## 1-2 Structural drawing

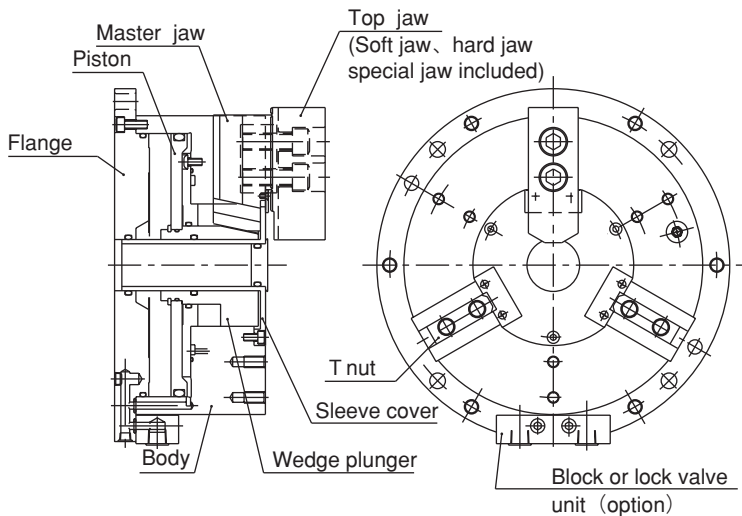

Fig. 2-1

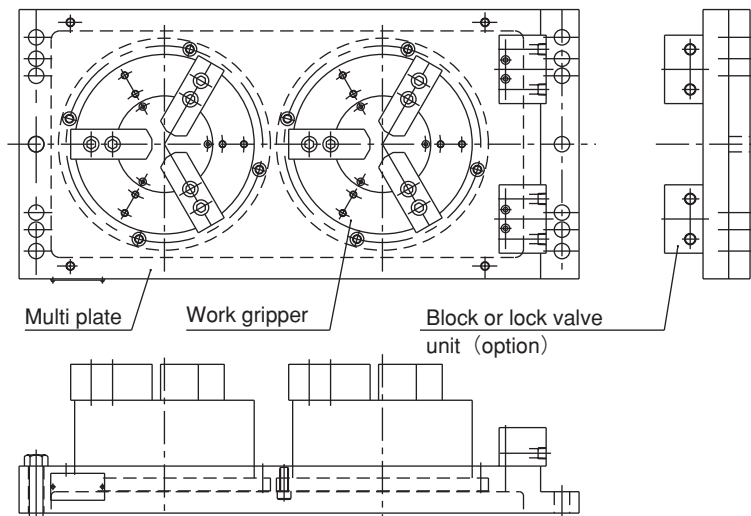

Fig. 2-2 Multi plate type

### 1-3 Scope of product

This instruction manual is for the work gripper. Other than information about the work gripper, it is mentioned about optional article (A lock valve unit and a multi plate).

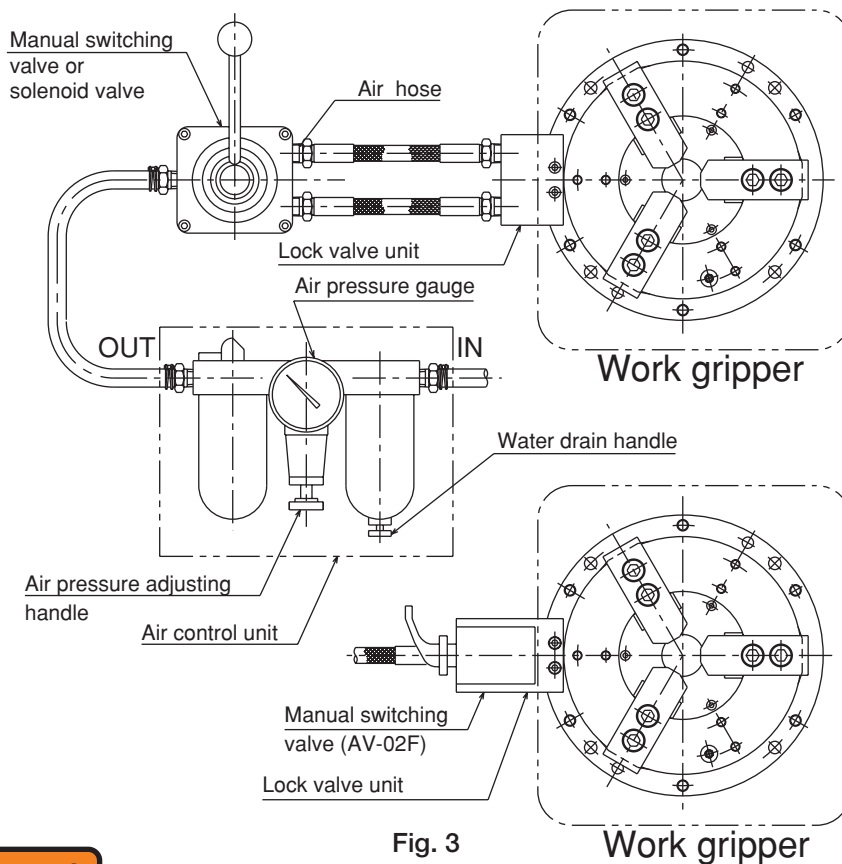

Fig. 3

**⚠ WARNING**

- To prevent the work from flying, safe design, maintenance and erroneous action prevention of the pneumatic system to maintain the gripping force of the work gripper is extremely important. Thoroughly read the “Important Safety Precautions” on and after page 8 in this manual.
- As for the other pneumatic products, follow the instruction manual for these products.

# 1-4 Parts list

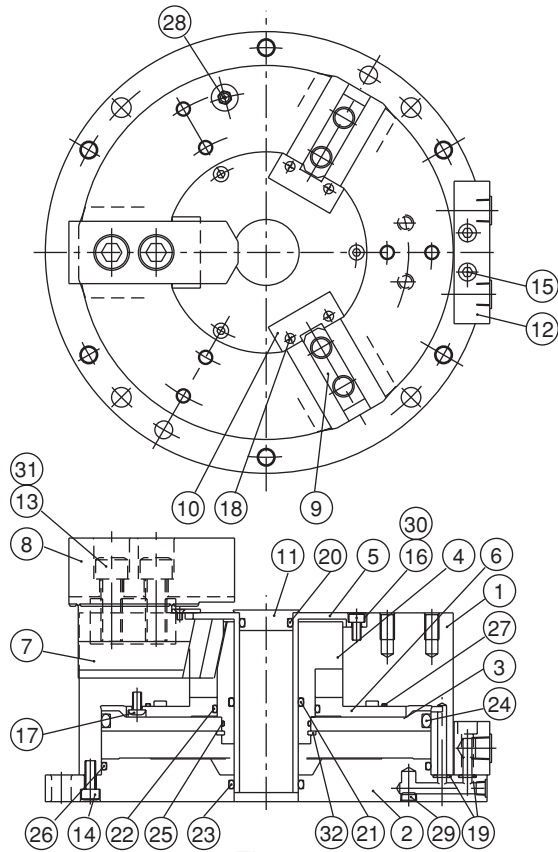

Fig. 4

Table 1

No.	Part name	Quantity	No.	Part name	Quantity
1	Body	1	18	Machine screw(06~10" )	4,6
2	Flange	1	19	O-ring	4
3	Piston	1	20	O-ring (06~10" )	1
4	Wedge plunger	1	21	O-ring (06~10" )	1
5	Sleeve cover	1	22	O-ring	1
6	Cylinder cover	1	23	O-ring (06~10" )	1
7	Master jaw	2,3	24	O-ring	1
8	Soft jaw	2,3	25	O-ring	1
9	T-nut	2,3	26	O-ring	1
10	Protector (06~10" )	2,3	27	O-ring	1
11	Coverlid (06~10" )	1	28	Grease nipple	1
12	Block	1	29	Plug	2
13	Jaw attaching bolt	4,6	30	Machine screw (Only 4" )	3
14	Cap screw	6,8,9	31	Hex. Key	1
15	Cap screw	2	32	Retaining ring	1
16	Cap screw (06~10" )	4,3	33	Eyebolt (Only 10" )	3
17	Button screw	4,6,8			

**Table 2 Consumable parts**

No.	Part name	AS04 AT04	AS06 AT06	AS08 AT08	AS10 AT10
19	O-ring	JIS B2401 P7	JIS B2401 P7	JIS B2401 P7	JIS B2401 P7
20	O-ring	—	JIS B2401 P16	JIS B2401 P24	JIS B2401 P36
21	O-ring	—	JIS B2401 P25	JIS B2401 P36	JIS B2401 P50
22	O-ring	JIS B2401 P22	JIS B2401 P40	JIS B2401 G55	JIS B2401 P70
23	O-ring	—	JIS B2401 G25	JIS B2401 P36	JIS B2401 G50
24	O-ring	JIS B2401 G80	JIS B2401 G135	JIS B2401 G175	JIS B2401 G210
25	O-ring	NOK S16	JASO 2031	NOK S46	JASO 2060
26	O-ring	NOK S80	NOK S135	AN6230-40	AN6230-45
27	O-ring	NOK S50	NOK S100	NOK S130	164×2

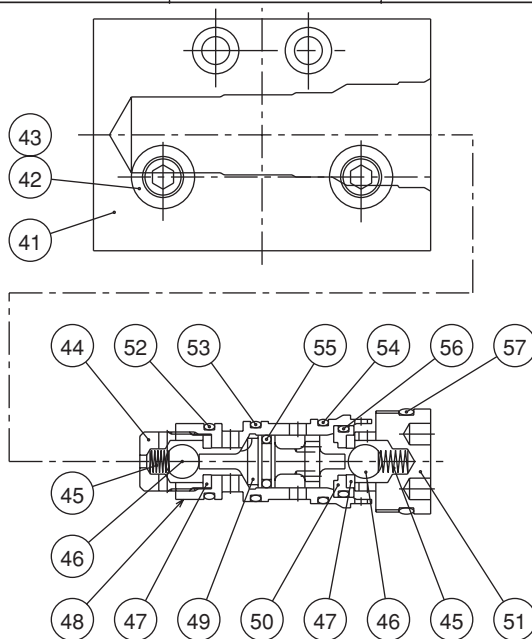

**Fig. 5 Lock valve unit**

**Table 3**

No.	Part name	Quantity	No.	Part name	Quantity
41	Block	1	51	Plug	1
42	Seal washer	2	52	O-ring JASO 1015	1
43	Cap screw	2	53	O-ring JASO 1016	1
44	Cap	1	54	O-ring JASO 1017	1
45	Spring	2	55	O-ring JIS B2401 P9	1
46	Ball $\phi$ 8	2	56	O-ring JASO 1014	1
47	Valve seat	2	57	O-ring JASO 1021	1
48	Housing	1	58	Hex. key 5	1
49	Pilot spool	1	59	Cap screw M6×50	2
50	Ring	1	60	Air pressure gauge	1

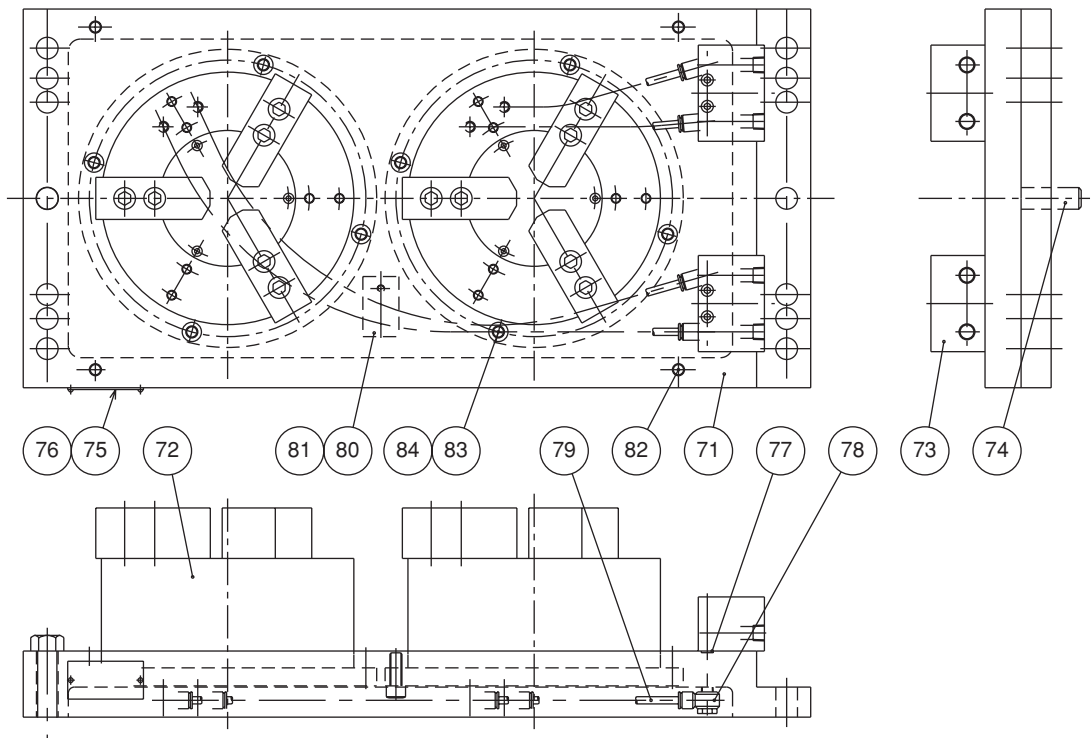

Fig. 6 Multi plate type

Table 4

No.	Part name	Quantity									
		AS04M2 AT04M2	AS04M4 AT04M4	AS04M6 AT04M6	AS06M2 AT06M2	AS06M4 AT06M4	AS06M6 AT06M6	AS08M2 AT08M2	AS08M4 AT08M4	AS10M2 AT10M2	AS10M4 AT10M4
71	Multi plate	1	1	1	1	1	1	1	1	1	1
72	Work gripper	~2	~4	~6	~2	~4	~6	~2	~4	~2	~4
73	Block	2	4	6	2	4	6	2	4	2	4
74	Parallel pin	2	2	2	2	2	2	2	2	2	2
75	Name plate	1	1	1	1	1	1	1	1	1	1
76	Screw rivet	2	2	2	2	2	2	2	2	2	2
77	O-ring P7	4	8	12	4	8	12	4	8	4	8
78	Universal elbow	8	16	24	8	16	24	8	16	8	16
79	Air tube	4	8	12	4	8	12	4	8	4	8
80	Clamp	—	—	2	2	2	2	2	2	2	2
81	Machine screw	—	—	2	2	2	2	2	2	2	2
82	Eyebolt	4	4	4	4	4	4	4	4	4	4
83	Cap screw	8	16	24	8	16	24	8	16	8	16
84	Hex. key	1	1	1	1	1	1	1	1	1	1



## 2. Important Safety Precautions

Important safety precautions are summarized below. Please read this section before first starting to use this product.



### DANGER

Failure to follow the safety precautions below will result in serious injury or death.



Turn off main power supply before attaching, inspecting or replacing work gripper, and before adding oil.

For All Users

- The machine tool may start rotation suddenly, and a part of the body or clothing may be caught.

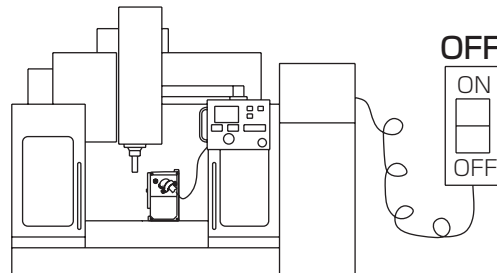

Close door before machining.

For All Users

- If the door is not closed, you may touch the tools or the work gripper, or the work may fly out, which is very dangerous. (In general, the safety interlock function which allows machining only when the door is the manual mode or the test mode)

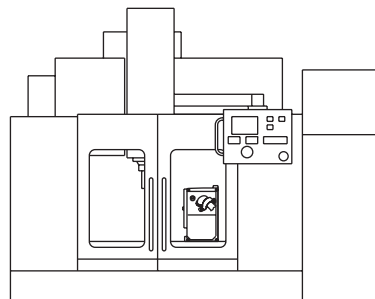

During machining, do not operate switching valve.

For All Users

- This is dangerous as the work will fly out.

Switching valve

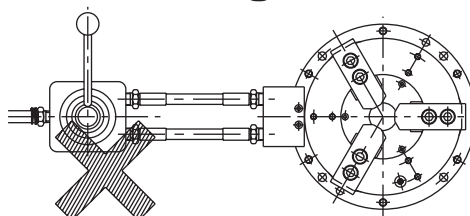



# DANGER

Failure to follow the safety precautions below will result in serious injury or death.



Always tighten the bolts at the specified torque. If the torque is insufficient or excessive, the bolt will break, which is dangerous as the work gripper or work will fly out. Use the bolts attached to the work gripper, and do not use bolts other than these. **For All Users**

- If the torque is insufficient or excessive, the bolt will break, which is dangerous as the work gripper or work will fly out.
- Fix the lathe spindle or the work gripper when you tighten bolts. Your hand could slip and get injury when you work without fixing the spindle.
- You cannot control the torque by a hex key. You must use a torque wrench for torque control.

Specified torque for socket head cap screw

Bolt size	Tightening torque	Bolt size	Tightening torque
M 5	7.5 N·m	M14	171 N·m
M 6	13 N·m	M16	250 N·m
M 8	33 N·m	M20	402 N·m
M10	73 N·m	M22	539 N·m
M12	107 N·m		

Tightening torque  
 $T = F \times L$   
 $= 127 \times 0.1$   
 $= 12.7 \text{ (N}\cdot\text{m)}$

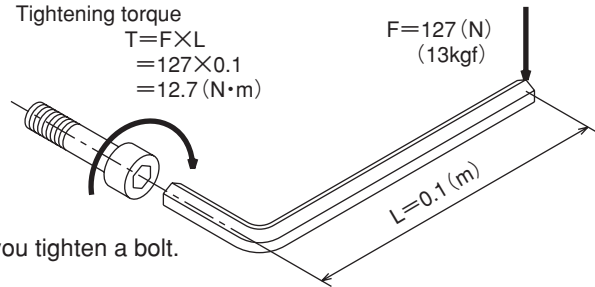

- Tightening torque is moment of force when you tighten a bolt.  
Tightening torque =  $F \times L$ .



# WARNING

Failure to follow the safety precautions below could result in serious injury or death.



Use a lock valve (safety valve, check valve) incorporated in case of sudden pneumatic pressure drop due to blackout, malfunction, etc. Further, use a solenoid valve with a circuit that retains the gripping position when no current is carried. (Refer to page 27) **For Machine Tool Manufacturers**

- If the pneumatic pressure suddenly drops due to blackout or malfunction, etc., this is dangerous as work will fly out.
- Lock valve retains the pneumatic pressure inside the cylinder temporarily, when the pneumatic pressure suddenly drops due to blackout or malfunction, etc. We prepare for the lock valve unit for exclusive use of the work gripper optionally.



When the protrusion of the work is long, support it with the steady rest or center. **For All Users**

- If the protrusion is long, the tip of the work can turn and the work fly out.

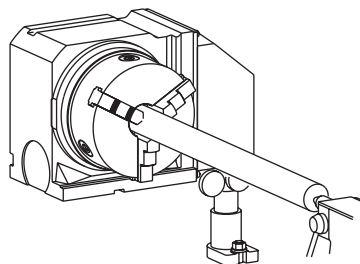



## WARNING

Failure to follow the safety precautions below could result in serious injury or death.



Do not use the work gripper on the lathe.

For All Users

- Gripping force is short by centrifugal force, or the work gripper may break and the work gripper or work could fly out.



Keep the height of the jaw within the range specified in the gripping force limit table. The air pressure must not exceed the max air pressure. (Refer to pages 13-14)

For All Users

- The work gripper will break and the work gripper and work will break and fly out.

H= gripping part center height

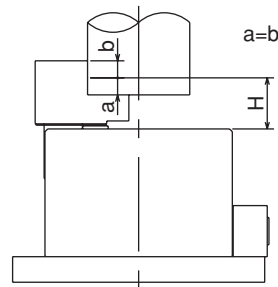

Determine the gripping force required for processing by the machine tool manufacturer or user, and check that the required gripping force is provided before processing. (Refer to pages 12-15)

For All Users

- Adjust the pneumatic pressure to obtain the required gripping force. If the gripping force is insufficient, this is dangerous as the work will fly out. Adjust the steering wheel of the reducing valve, and set it to prescribed pressure. Afterwards, tighten the lock nut, and prevent the setting pressure from carelessly changing.



Always fill lubricator with oil up to proper level. Periodically drain water in the filter. (Refer to each instruction manual for the details.)

For All Users

- Rust may occur in the cylinder, the work scatters due to the defective operation and the decrease of the gripping force, and it is dangerous.



# WARNING

Failure to follow the safety precautions below could result in serious injury or death.



Do not modify the work gripper in a way not permitted by the manufacturer.

For All Users

- It may not only break the work gripper but the work gripper and the work may fly out, which is dangerous.
- If you attach a locator or jig on the work gripper body surface, only process work in an acceptable range (Refer to pages 21-22).

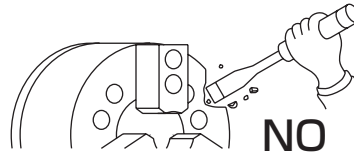

Periodically supply adequate grease (Refer to page 23).  
Turn off power before adding grease.

For All Users

- Insufficient grease supply lowers the gripping force, causes operation failure due to lower hydraulic pressure, lowers the gripping precision, and causes abnormal wearing and seizing, etc.
- This is dangerous as the work could fly out from a drop in the gripping force.

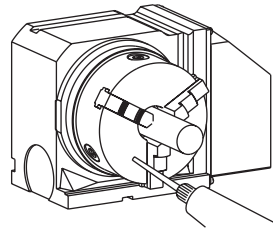

Do not operate the machine after drinking alcohol or taking medication.

For All Users

- Dangerous since these lead to operation mistakes and misjudgment.

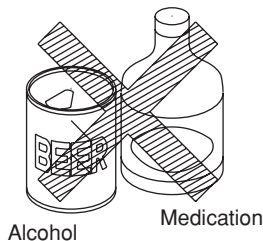

Alcohol

Medication



Do not operate the machine wearing gloves, a necktie, and other loose clothing or jewelry.

For All Users

- Dangerous since it will be caught.



Do not grip a chuck with a chuck.

すべての方へ

- Because it is easy to confuse the specifications of each work gripper and the protrusion become long and is apt to exceed the specifications, it is apt to exceed the specifications of the base chuck. The work gripper may break and the work gripper or work could fly out.

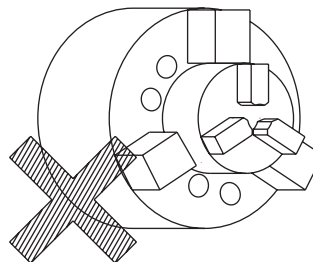

# 3 . Specifications

## 3-1 Specifications

Table 5-1

Type		AS04	AS06	AS08	AS10
Plunger stroke	mm	15	15	15	15
Jaw stroke (in diameter)	mm	5.2	5.2	6.3	6.3
Gripping force (Air pressure : 0.6MPa)	kN (kgf)	7.5 (765)	21 (2140)	33 (3365)	48 (4895)
Standard soft jaw height (Z axis)	mm	27	36	42	46
Gripping range (outside diameter gripping)	mm	φ 8~110	φ 26~165	φ 38~210	φ 53~254
Mass (standard soft jaw included)	kg	7.3	16	27.7	42.5
Nominal operating pressure	MPa (kgf/cm <sup>2</sup> )	0.2 ~ 0.6 (2 ~ 6)			
Max air pressure	MPa (kgf/cm <sup>2</sup> )	0.7 (7)			
Air consumption (Plunger stroke 10mm, 0.6MPa)	NI	0.4	1.04	1.81	2.52
Storing temperature / Operating temperature		-20~+50°C / -10~+40°C			

Reference: 1kN = 101.97kgf 1MPa = 10.197kgf/cm<sup>2</sup>

When storing this product, the product should be subjected to the antirust treatment and stored in a place free from wetting, condensation, or freeze.

Table 5-2

Type		AT04	AT06	AT08	AT10
Plunger stroke	mm	15	15	15	15
Jaw stroke (in diameter)	mm	5.2	5.2	6.3	6.3
Gripping force (Air pressure : 0.6MPa)	kN (kgf)	7.5 (765)	21 (2140)	33 (3365)	48 (4895)
Standard soft jaw height (Z axis)	mm	27	36	42	46
Gripping range (outside diameter gripping)	mm	φ 9~110	φ 31~165	φ 41~210	φ 61~254
Mass (standard soft jaw included)	kg	6.9	15	26.7	40.8
Nominal operating pressure	MPa (kgf/cm <sup>2</sup> )	0.2 ~ 0.6 (2 ~ 6)			
Max air pressure	MPa (kgf/cm <sup>2</sup> )	0.6 (6)			
Air consumption (Plunger stroke 10mm, 0.6MPa)	NI	0.4	1.04	1.81	2.52
Storing temperature / Operating temperature		-20~+50°C / -10~+40°C			

Reference: 1kN = 101.97kgf 1MPa = 10.197kgf/cm<sup>2</sup>

When storing this product, the product should be subjected to the antirust treatment and stored in a place free from wetting, condensation, or freeze.

## 3-2 Relationship between air pressure and gripping force

### 1. Gripping force

The work gripper has a mechanism to convert air pressure from the built-in cylinder to gripping force. The gripping force specified in the specification is the value that the air pressure is 0.6 MPa.

However, the gripping force is different depending on the state of grease lubrication, grease in use, height of the jaw, etc.

The gripping force specified in the specification is the value under the following conditions:

- The Kitagawa standard soft jaw is used as the jaw.
- The attaching bolts of the soft jaw are tightened at the specified torque. (Refer to page 9)
- The numerical values are obtained with the Kitagawa gripping force meter. The gripping position of the gripping force meter is at a position 1/2 of the height of the soft jaw top surface (height from the chuck surface to the top surface of the jaw).
- CHUCK GREASE PRO is used. (Refer to page 23).
- The air pressure is 0.6 MPa.

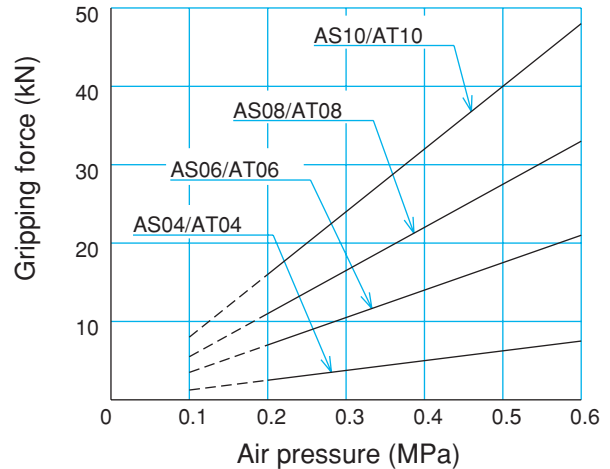
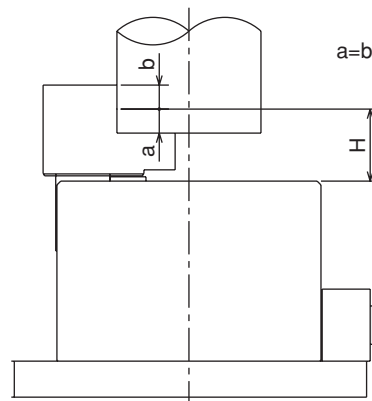

Fig. 7

## 3-3 Relationship between gripping part center height, gripping force and air pressure

The gripping force is different depending on the gripping part center height of top jaw (Dimension H in Fig.8).

If a top jaw is taller than the standard soft jaw, determine the air pressure and the gripping force by the gripping force limit table. (Refer Fig.9 and Fig.10)



H : Gripping part center height

Fig. 8

### ⚠ WARNING

- Keep the height of the top jaw within the range of the gripping force limit table.
- In the case of using only 1 jaw for gripping reduce the air pressure by 2/3 or more with 3 jaw work gripper. If 2 jaws are used for gripping reduce the air pressure by 1/3 or more with 3 jaw work gripper. If 1 jaw is used for gripping reduce the air pressure by 1/2 or more with 2 jaw work gripper. If it is used without lowering the air pressure, the gripping force which is normally applied evenly onto 3 of the jaws is concentrated onto 1 or 2 of the jaws. Otherwise the work gripper will break, the work will fly out and this is dangerous.

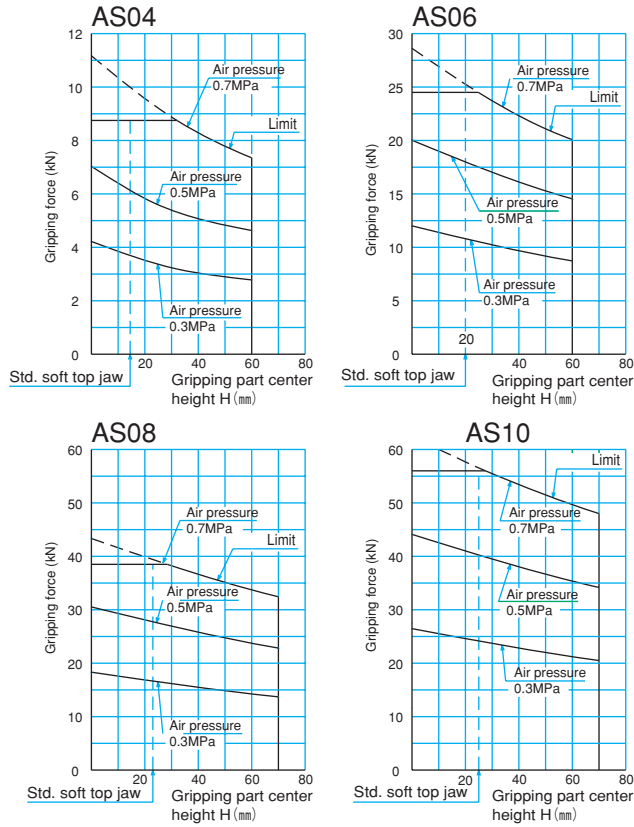

Fig. 9

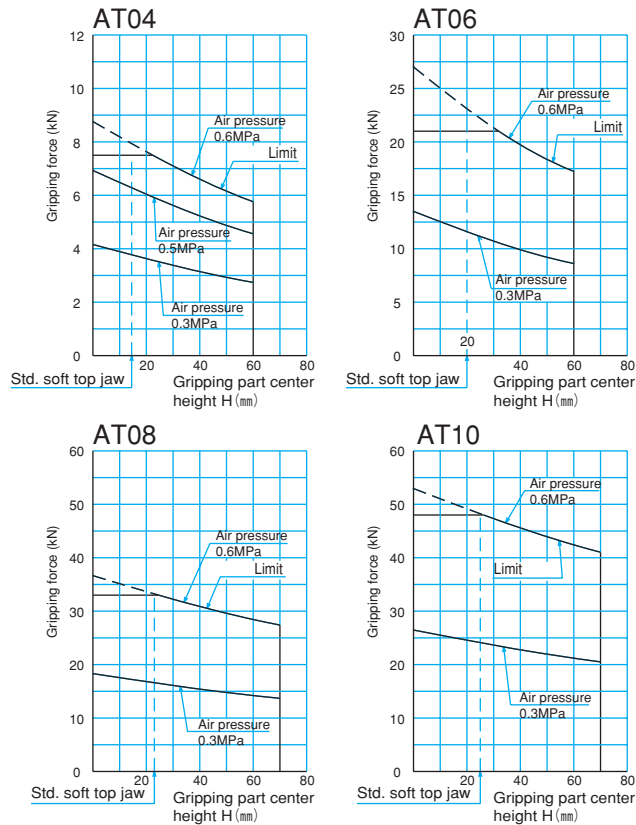

Fig. 10

## Cutting condition

As a review method of cutting condition, the following shows a calculation example in the case where the moment load is put on the workpiece by a drilling. The final cutting condition, however, must be determined by a test cutting.

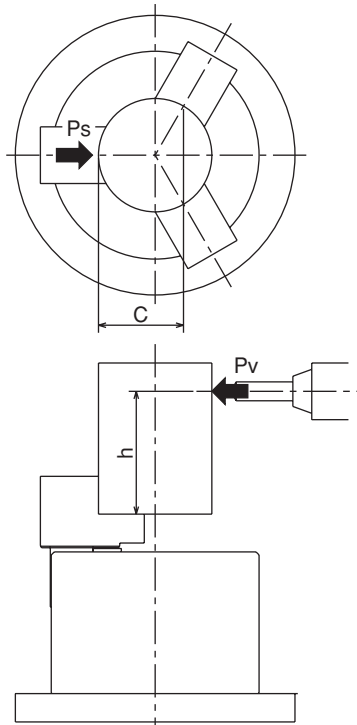

Fig. 11

$$\frac{\mu \times P_s \times C}{P_v \times h} = S > 2.5$$

$P_s$  : Gripping force per a jaw

$\mu$  : Gripping surface friction coefficient between jaw and workpiece. In general, 0.1 is used when both are smooth surfaces.

$P_v$  : Drilling thrust

$S$  : Factor of safety



# 4 . Forming Soft Jaw

## 4-1 Attachment of soft jaw

The attaching position of the soft jaw can be adjusted by loosening the socket head cap screw, attaching the soft jaw and by changing each serration engagement position.

Use the most appropriate soft jaw considering the shape, dimension, material, and surface roughness of the work and the cutting conditions, etc.



- Use the T nut so that it does not come out from the master jaw. (Refer to Fig.12)
- If the T nut comes out from the master jaw, the master jaw and T nut will break causing the work to fly out and a possible precision failure.

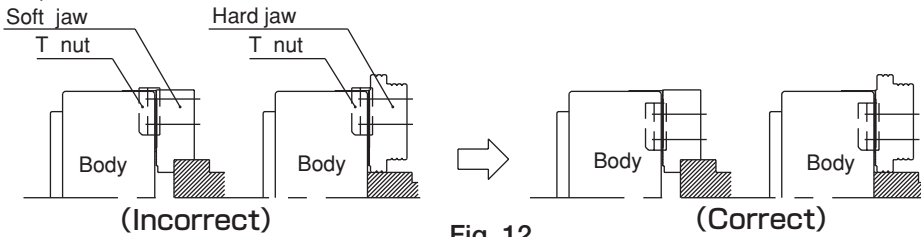

Fig. 12

- Always tighten the bolts at the specified torque. If the torque is insufficient or excessive, the bolt will break, which is dangerous as the chuck or work will fly out.

Table 6

Bolt size	Tightening torque	Bolt size	Tightening torque	Bolt size	Tightening torque
M 5	7.5 N·m	M10	73 N·m	M16	250 N·m
M 6	13 N·m	M12	107 N·m	M20	402 N·m
M 8	33 N·m	M14	171 N·m	M22	539 N·m



- If the screw-in depth of the jaw attaching bolt to the T nut is shallow, the T nut will break, and this is dangerous as the jaw and work will fly out. If the attaching bolt is too long and comes out from the bottom of the T nut as well, this is dangerous as the jaw and work will fly out since the top jaw is not fixed. Therefore, the overall length of the jaw attaching bolt must be approximately 0 to -1mm from the bottom of the T nut (Refer to Fig.13).
- Use the T nut and the attaching bolts attached to the chuck and do not use bolts other than these. If commercially available bolts are used for an unavoidable reason, use bolts at the strength classification 12.9 (strength classification 10.9 for M22 or more) or more, and pay sufficient attention to the length.
- Do not rotate the work gripper so that the T nut is loosened causing the jaw to fly out.
- Check that the reference mark on the side of the No. 1 master jaw is within the range of the entire stroke as shown in Fig. 14. Full stroke the jaw at least once a day to check it before work or when supplying grease, etc.
- When gripping the work, use it by keeping the position of the master jaw within the appropriate stroke range. Gripping in the center of the stroke is the most stable for the mechanism, and the best precision can be obtained.
- When gripping near the stroke end, the work may not be gripped sometimes according to the deviation, etc., of the gripping part allowance of the work, and this is dangerous as the work will fly out.
- When gripping near the stroke end, the chuck may break and the chuck or work could fly out.

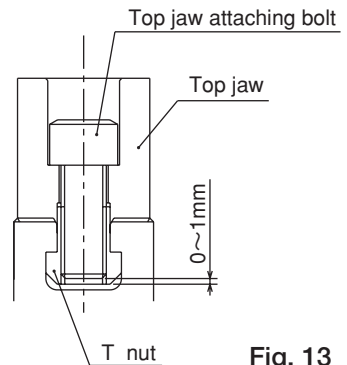

Fig. 13

Table 7

Type	AS04 AT04	AS06 AT06	AS08 AT08	AS10 AT10
Appropriate stroke range (mm)	1	1	1.6	1.6

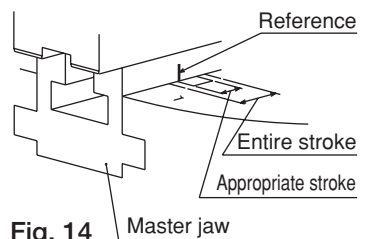
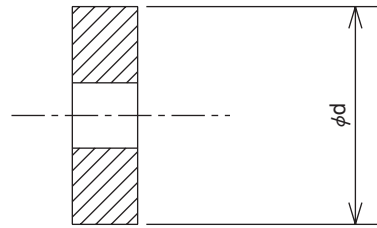

Fig. 14

## 4-2 Forming soft jaw with outside diameter gripping

### 1. Preparation of the plug for forming

- Prepare the plug for forming. The surface roughness of the plug outside diameter is to be approximately  $25s$ , and make a shape with sufficient thickness which does not distort.
- It is convenient to prepare various outside diameter dimensions for dimensions of forming parts.
- It is convenient to process tapping in the center part of the plug and to guide with a bolt, etc.



### 2. Process of the plug gripping part for forming

- Operate the switch valve and maximize the opening of the jaw.
- Then, process the  $\phi D$  part (part to grip the plug for forming). Set the dimension  $\phi D$  so that gripping near the center of the jaw maximum stroke (diameter) is possible.
- $\phi D = \phi d + (\text{jaw maximum stroke}/2)$

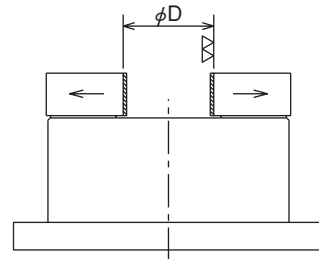

### 3. Gripping of the plug for forming

- By operating the switch valve, grip the plug for forming in the  $\phi D$  part. At this time, grip by pressing the plug on the chuck front surface in order for the plug not to be tilted. Repeat chucking several times to stabilize the plug.

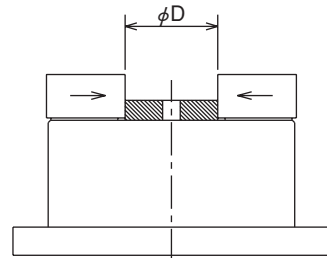

### 4. Forming

- Process the gripping part (dimension  $\phi D'$ ) of the work in the state that the plug is kept gripped. The  $\phi D'$  part is to be approximately the same diameter (H7) as the diameter of the gripping part of the work, and process to be surface roughness at  $6s$  or less.
- Set the hydraulic pressure during forming the same as during processing of the work, or slightly higher.
- When the plug distorts, lower the hydraulic pressure or change the plug into a shape which does not easily distort.

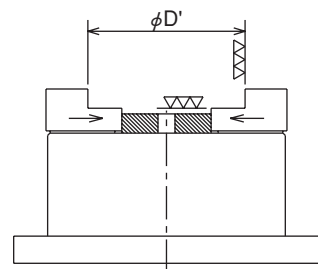

### 5. Trial cutting

- Remove the plug for forming and grip the work to check the jaw stroke.
- Implement trial cutting to check the process precision and that there is no slip, etc.
- Contacting on the gripping surface is to be 2 points contact of the side A and the side B when gripping.

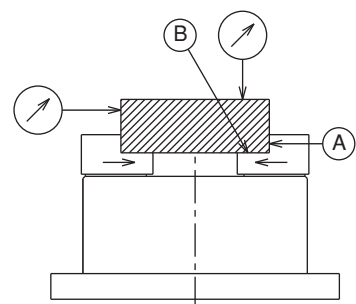

## 4-3 Forming soft jaw with inside diameter gripping

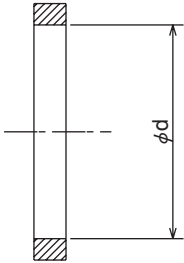
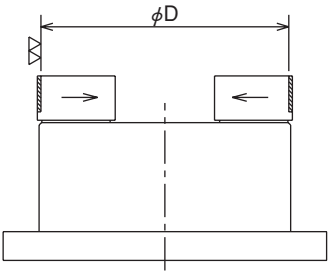
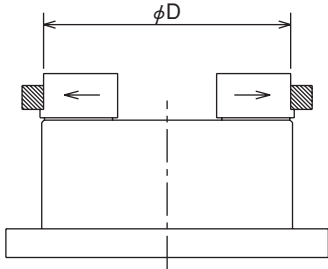
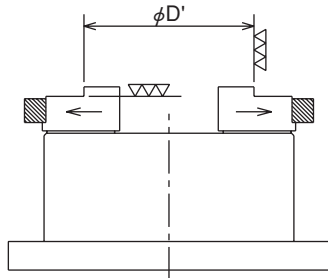
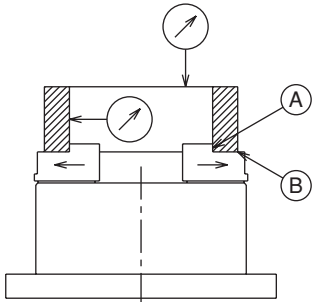
<p>1. Preparation of the ring for forming</p> <ul style="list-style-type: none"> <li>Prepare the ring for forming. The surface roughness of the ring inside diameter is to be approximately 25s, and make a shape with a sufficient thickness which does not distort.</li> <li>It is convenient to prepare various inside diameter dimensions for dimensions of forming parts.</li> </ul>	
<p>2. Process of the ring gripping part for forming</p> <ul style="list-style-type: none"> <li>Operate the switch valve and minimize the jaw to close.</li> <li>Then, process the <math>\phi D</math> part (part to grip the ring for forming). Set the dimension <math>\phi D</math> so that gripping near the center of the jaw maximum stroke (diameter) is possible.</li> <li><math>\phi D = \phi d - (\text{jaw maximum stroke}/2)</math></li> </ul>	
<p>3. Gripping of the ring for forming</p> <ul style="list-style-type: none"> <li>By operating the switch valve, grip the ring for forming in the <math>\phi D</math> part. At this time, grip by pressing the ring on the jaw in order for the ring not to be tilted. Repeat chucking several times to stabilize the ring.</li> </ul>	
<p>4. Forming</p> <ul style="list-style-type: none"> <li>Process the gripping part (dimension <math>\phi D'</math>) of the work in the state that the ring is kept gripped. The <math>\phi D'</math> part is to be approximately the same diameter (H7) as the diameter of the gripping part of the work, and process to be surface roughness at 6s or less.</li> <li>Set the hydraulic pressure when forming the same as when processing of the work, or slightly higher. Additionally, in the case of inside diameter gripping, it is necessary to use the input at 1/2 of the allowable maximum input or less.</li> <li>When the ring distorts, lower the hydraulic pressure or change the ring into a shape which does not easily distort.</li> </ul>	
<p>5. Trial cutting</p> <ul style="list-style-type: none"> <li>Remove the ring for forming and grip the work to check the jaw stroke.</li> <li>Implement trial cutting to check the process precision and that there is no slip, etc.</li> <li>Contacting on the gripping surface is to be 2 points contact of the side A and the side B when gripping.</li> </ul>	

## 4-4 Forming method when you use forming jig

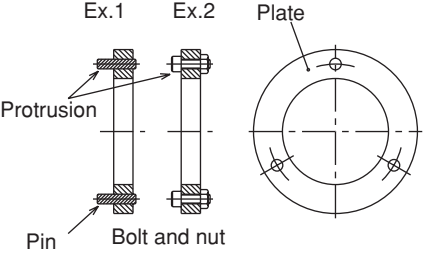
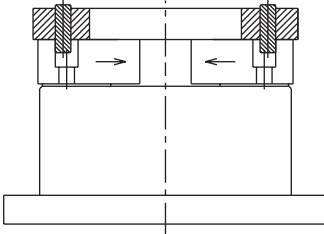
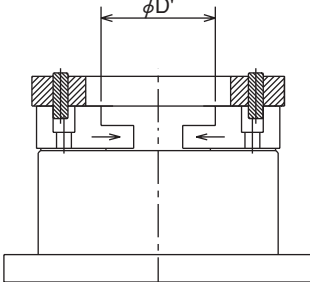
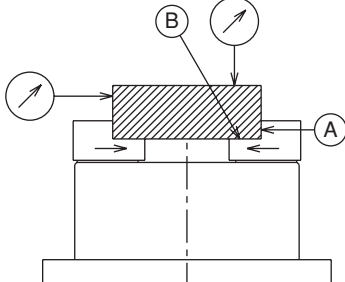
<p><b>1 . Preparation of the jig for forming</b></p> <ul style="list-style-type: none"> <li>• Prepare the jig for forming. (There is a commercially available product.)</li> <li>• Attach the pin (Example 1) or the bolt and nut (Example 2) by dividing equally into 3 portions onto the ring shape plate. Make the ring into a shape with sufficient thickness which does not distort.</li> </ul>	 <p>Ex.1 Ex.2 Plate Protrusion Pin Bolt and nut</p>
<p><b>2 . Gripping of the jig for forming</b></p> <ul style="list-style-type: none"> <li>• Operate the switch valve and maximize the opening of the jaw. Then, operate the switch valve to insert the jig for forming into the bolt hole of the soft jaw to grip. At this time, grip by pressing the ring end surface of the jig for forming onto the jaw so as not to generate run-out.</li> <li>• Check that it is gripping almost in the center of the appropriate stroke.</li> <li>• Set the hydraulic pressure when forming slightly higher than when processing the work.</li> </ul>	
<p><b>3 . Forming</b></p> <ul style="list-style-type: none"> <li>• Process the gripping part (dimension <math>\phi D'</math> ) of the work in the state that the jig for forming is kept gripped. The <math>\phi D'</math> part is to be approximately the same diameter (H7) as the diameter of the gripping part of the work, and process to be surface roughness at 6s or less.</li> </ul>	
<p><b>4 . Trial cutting</b></p> <ul style="list-style-type: none"> <li>• Remove the jig for forming and grip the work to check the jaw stroke.</li> <li>• Implement trial cutting to check the process precision and that there is no slip, etc.</li> <li>• Contacting on the gripping surface is to be 2 points contact of the side A and the side B when gripping.</li> </ul>	

## 5 . Usage

This product is a device to fix a work-piece when it is processed by the rotary table or the machining center. A built-in cylinder closes the jaw and fixes a work-piece so that it does not move during processing. The chuck opens the jaw after having processed it and remove a work-piece.

### NOTICE

- When replacing the top jaw, carefully clean the serration part with the master jaw, and the engagement part of the T nut. Failure to do this may cause a precision failure.
- Set the air pressure according to the shape of the work and the cutting conditions. Pipe shape work, etc., may be distorted if they are tightened at a high gripping force.

### 5-1 Precautions during gripping work with work gripper

#### DANGER

- When gripping a work with the chuck, do not get fingers or hands become caught. This could cause crushed or cut fingers and hands.

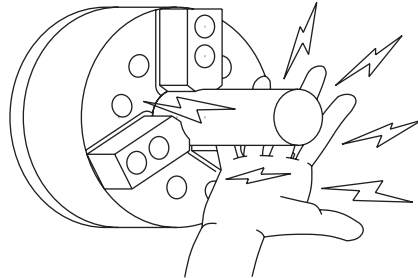

### 5-2 Precautions during gripping work in irregular shape

#### WARNING

- If a work in an irregular shape is gripped the master jaw may be broken. Consult our company or the distributor if there is any concern.
- Cast metal, pitched shape or taper shape cannot be gripped.
- If the protrusion of the work is long, support it with a center or the steady rest. If the protrusion is long the tip of the work turns, and this is dangerous as the work will fly out.

### 5-3 Precautions related to usage of jaw

#### WARNING

- If a soft jaw other than one made by Kitagawa Corporation is used, the engagement will be inferior, and the master jaw will be deformed, the gripping precision will worsen, and the work will fly out due to gripping failure, which is dangerous.
- Do not use a top jaw with a different serration pitch from the master jaw. The engagement of the crests of the serration will become insufficient, therefore, the serration crests will break when gripping the work, and this is dangerous as the jaw and work will fly out.
- Do not use the soft jaw by welding to join for extension. The jaw will break due to insufficient strength and the serration part will become distorted due to welding. As a result, the engagement will worsen, the serration crests will break, and this is dangerous as the work will fly out.

## 5-4 Precautions related to processing



**WARNING**

### < 1 > Interference, contact, impact

- Before starting work, check that the top jaw, locator, work, etc., and the tool and the tool post, etc., do not interfere at low rotation and then start processing.
- Do not allow anything to impact the work gripper, jaw, and the work. The work gripper will break and this is dangerous as the work gripper and work will fly out.
- If the tool and the tool post contact the work gripper or the work due to malfunction or tape mistake, etc., and impact is given, immediately stop the machining, and check that there are no abnormalities in the top jaw, master jaw, T nut and bolts of each part, etc.

### < 2 > Coolant

- Unless coolant with a rust preventive effect is used, rust will occur inside the work gripper and gripping force drop may result. The work will fly out due to the gripping force drop and this is dangerous.

## 5-5 Attachment of locator and jig

- In the case of attaching the locator and the jig on the chuck body surface, tap or drill a hole in the additional process range specified in Fig. 15-16.

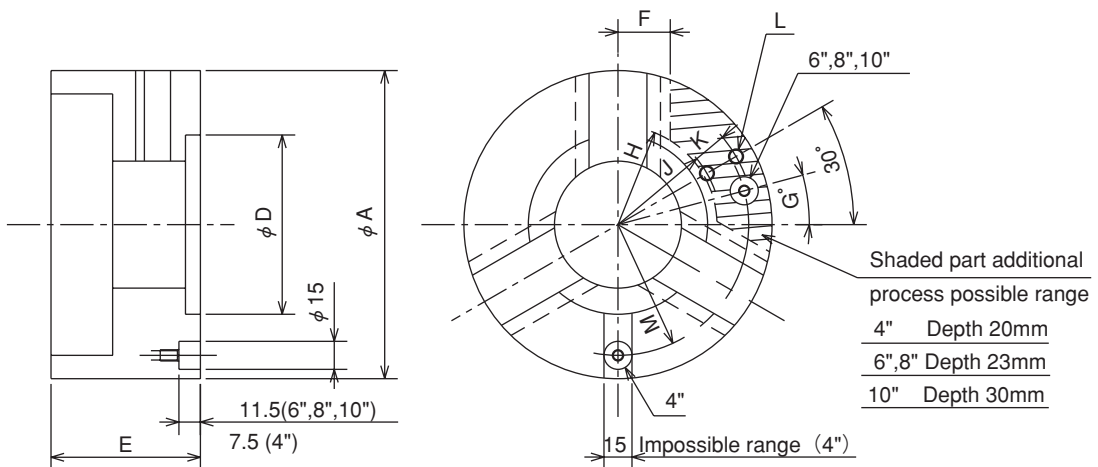

Fig. 15

Table 8-1

Type	A	D	E	F	G	H	J	K	L	M
AS04	110	61	75	23	—	35.5	—	—	—	43
AS06	165	96	80	28	15°	53	55	18	6-M8	70
AS08	210	113	91	31	15°	61.5	68	25	6-M8	90
AS10	254	139	94	34	10°	74.5	85	30	6-M10	110

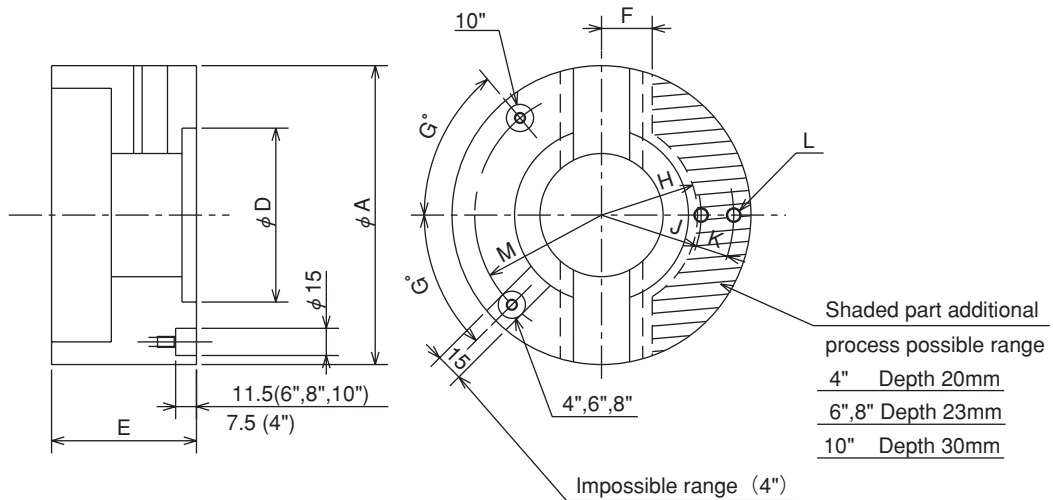

Fig. 16

Table 8-2

Type	A	D	E	F	G	H	J	K	L	M
AT04	110	61	75	23	30°	35.5	—	—	—	43
AT06	165	96	80	28	45°	53	55	18	4-M8	70
AT08	210	113	91	31	45°	61.5	68	25	4-M8	90
AT10	254	139	94	34	50°	74.5	85	30	4-M10	110

**WARNING**

- The work gripper can be modified only in the manufacturer permissible range. This will not only break the work gripper but the work gripper and work may fly out, which is dangerous.
- Provide a countermeasure against flying out (dwell pin, etc.) due to centrifugal force to the locator or the jig, and attach with bolts which have sufficient strength. The locator or the jig may fly out, and this is dangerous.

## 5-6 Precautions related to usage of lock valve unit

### Lock valve unit

Lock valve retains the pneumatic pressure inside the cylinder temporarily, when the pneumatic pressure suddenly drops due to blackout or malfunction, etc. We prepare for the lock valve unit for exclusive use of the work gripper optionally.

The air pressure in the work gripper is sealed up by using the lock valve unit. Therefore, it is possible to machining a workpiece without piping.

**WARNING**

- If the air supply is stopped and the workpiece is held for a long time using the lock valve unit, before start of the work, measure the pressure retention time to make sure that the internal pressure does not drop. Reduction in gripping force due to the internal pressure drop causes the workpiece to fly out.

# 6. Maintenance and Inspection

## 6-1 Periodic Inspection

- Add grease at least once a day.
- Fully stroke the jaw before starting work or upon supplying grease, and check that the jaw is inside the appropriate stroke area. (Refer to page 16)
- Always clean the chuck body or the sliding surface using an air gun, etc., at the end of work.
- Periodically drain water in the filter.
- Always fill lubricator with oil up to proper level.
- When the lock valve unit is used, confirm whether there will not be the decrease in inner pressure because of the air leakage in at least once a week. (Refer to Page 25)
- Check that the bolts of each part are not loosened at least once every 3 months.
- Disassemble and clean at least once every 6 months or every 100,000 strokes (once every 2 months or more for cutting cast metal).

## 6-2 Grease lubrication

### 1. Position to lubricate

- Lubricate using a grease gun from the grease nipple on the body periphery part or each master jaw periphery part. Supply grease when the jaw is open. After lubrication, repeat opening and closing the jaw several times without gripping work.

### 2. Grease to use

- Use the designated grease specified in Table 9. If grease other than the designated grease is used, sufficient effect may not be obtained.

Table 9

Genuine product	CHUCK GREASE PRO	Kitagawa genuine product (Kitagawa distributor of each country)
Conventional product	Kitagawa chuck grease	Conventional product
	Molykote EP Grease	TORAY Dow Corning (only inside Japan)
	Chuck EEZ grease	Kitagawa-Northtech Inc. (North American region)
	MOLYKOTE TP-42	Dow Corning (Europe, Asian region)
	Klüberpaste ME31-52	Klüber lubrication (worldwide)

### 3. Frequency of lubrication

- Add grease once every day.
- In the case of high rotation or in the case of using a large amount of water soluble coolant, increase the frequency of lubrication according to the usage conditions.

#### WARNING

- To keep the chuck running in the best condition for a long time, adequate grease lubrication is necessary. Insufficient grease lubrication causes a drop in the gripping force, operation failure at low hydraulic pressure, drop in gripping precision, abnormal wearing, seizing, etc. The work will fly out due to a drop in the gripping force and this is dangerous.



## 4. Safety information about grease and anti-rust oil

### Applicable range

- Designated grease
- Antirust agent applied to the product at the delivery.

### First aid measures

After inhalation: Remove victim to fresh air. If symptoms persist, call a physician.

After contact with skin: Wash off with mild cleaners and plenty of water. If symptoms persist, call a physician.

After contact with eyes: Rinse with plenty of water. If symptoms persist, call a physician.

After ingestion: If large amounts are swallowed, do not induce vomiting. Obtain medical attention.

- Please refer to each MSDS about the grease and the anti-rust oil which you prepared.

## 6-3 Disassembling

### Disassembling procedures

Read the following disassembling procedures with reference to pages 5-7.

1. Turn off the main power of the machine before starting work.
2. If the lock valve unit is used, loosen slowly two cap screws [43] while bleeding the air gradually from the inside, and after making sure that the air is expelled completely, remove the screws.
3. Loosen the jaw attaching bolt [13] and remove the soft jaw [8] and the T nut [9].
4. Loosen the machine screw [18] and remove the protector [10].
5. Loosen the cap screw [14] and remove the flange [2].
6. Remove the Retaining ring [32] and remove the piston [3].
7. Loosen the button screw [17] and remove the cylinder cover [6].
8. Loosen the cap screw [16] or the machine screw [30] and remove the sleeve cover [5].
9. Remove the wedge plunger [4] to the chuck rear side.
10. Remove the master jaw [7] to the outer periphery side of the chuck.
11. Assemble again while sufficiently coating the recommended grease in the reverse procedures of disassembling. At this time, pay sufficient attention so as not to make a mistake in the numbers of the body [1], master jaw [7], and the wedge plunger [4].  
Moreover, exchange O-rings of each part if necessary.
12. Refer to page 27 about the installation procedure. (8. Attachment).

### CAUTION

- Use an eyebolt when attaching and detaching the chuck to and from the machine, as there is a danger of injury or damage if the work gripper drops.

Size	Eyebolt
4"	None
6"	M8
8"	M8
10"	M10

 **WARNING**

- Be sure to remove the eyebolt after use. If the machining starts without removing the eyebolt, it will interfere with a tool, causing the bolt or tool to fly out.
- Disassemble and clean the work gripper at least once every 6 months or every 100,000 strokes (once every 2 months or more for cutting cast metal). If cutting powder or other substances stagnate inside the work gripper, it will lead to insufficient stroke and a drop in the gripping force, and this is dangerous as the work will fly out. Check each part carefully and replace any part that is worn or cracked.
- Before disassembling the work gripper, remove the cap screw to bleed the air. Loosen slowly the cap screw while bleeding the air gradually from the inside, and after making sure that the air is expelled completely, remove the cap screw. With internal pressure applied, disassembling the work gripper causes the parts to fly out.
- After inspection, apply sufficient grease in the designated areas and reassemble.
- After assembling, measure the gripping force according to the method on page 13, and check that the specified gripping force is obtained.
- If you stop the machine for a long period of time, remove the work from the machine. If you don't, the work can drop due to a drop in the air pressure or the cylinder can stop or malfunction.
- If you stop the machine or store the work gripper for a long period of time, add grease to prevent rust.

## 6-4 Inspection of lock valve unit

When the lock valve unit is used, confirm whether there will not be the decrease in inner pressure because of the air leakage in at least once a week. Read the following procedures with reference to pages 5-7.

1. Loosen slowly two cap screws [43] while bleeding the air gradually from the inside, and after making sure that the air is expelled completely, remove the cap screws.
2. Install the pressure gauge [60] and set it to 0.5—0.6 MPa, and stop the air supply.
3. If the pressure drop per hour exceeds 0.05MPa, the lock valve unit must be repaired or replaced.

 **WARNING**

- Loosen slowly the cap screw while bleeding the air gradually from the inside, and after making sure that the air is expelled completely, remove the cap screw. With internal pressure applied, disassembling the work gripper causes the parts to fly out.
- If the air supply is stopped and the workpiece is held for a long time using the lock valve unit, before start of the work, measure the pressure retention time to make sure that the internal pressure does not drop. Reduction in gripping force due to the internal pressure drop causes the workpiece to fly out.

# 7 . Malfunction and Countermeasures

## 7-1 In the case of malfunction

Check the points specified in the table below and take the appropriate countermeasure.

Table 10

Defective	Cause	Countermeasure
The work gripper does not operate.	The work gripper inside will break.	Disassemble and replace the broken part.
	The sliding surface is seized.	Disassemble, correct the seized part with oilstone, etc., or replace the part.
	The cylinder is not operating.	Check the piping and the electric system, and if there is no abnormality, disassemble and clean the cylinder.
	Malfunction of lock valve unit.	Repair or replace the lock valve unit.
Insufficient stroke of the jaw.	A large amount of cutting powder is inside.	Disassemble and clean.
	Rust might occur.	
The Work slips.	The stroke of the jaw is insufficient.	Adjust so that the jaw is near the center of the stroke when gripping the work.
	The gripping force is insufficient.	Check that the correct hydraulic pressure is obtained.
	The forming diameter of the top jaw is not consistent with the work diameter.	Form again based on the correct forming method.
	The cutting force is too large.	Calculate the cutting force and check that it is suitable for the specification of the work gripper.
	Insufficient grease lubrication.	Supply grease from the grease nipple, and open and close the jaw several times without gripping a work.
Precision failure.	The outer periphery of the work gripper is running out.	Check the end surface run-out and the outer periphery, and retighten the attaching bolts.
	Dust is attached on the serration part of the master jaw and the top jaw.	Remove the top jaw, and clean the serration part thoroughly.
	The attaching bolt of the top jaw is not tightened sufficiently.	Tighten the top jaw attaching bolt at the specified torque. (Refer to page 16)
	The forming method of the soft jaw is inappropriate.	Is the plug for forming parallel to the work gripper end surface? Is the plug for forming not deformed due to the gripping force?
	The height of the top jaw is too high, the top jaw is deformed, the top jaw attaching bolt is elongated.	Lower the height of the top jaw. (Replace it with the standard size) or check the gripping contact surface and make it uniform.
	The gripping force is too large leading to the work being deformed.	Lower the gripping force in the range possible to process to prevent deformation.

### WARNING

- If the work gripper failed due to a seizure or breakage, remove the work gripper from the machine, following the disassembly steps in page 24. When the work gripper cannot be removed due to a blockage of workpiece, do not disassemble forcibly but please contact us or our agent.
- If these countermeasures do not correct the problem or improve the situation. Immediately stop using the machine. Continuous use of a broken product or a defective product may cause a serious accident by the chuck or the work flying out.
- Only experienced and trained personnel should do repairs and fix malfunctions. Repair of a malfunction by a person who has never received instruction from an experienced person, the distributor or our company may cause a serious accident.

## 7-2 Where to contact in the case of malfunction

In the case of malfunction, contact the distributor where you purchased the product or our branch office listed on the back cover.

# For Machine Tool Manufactures

Following pages are described for machine tool manufacturers (personnel who attach a chuck to a machine). Please read following instruction carefully when you attach or detach a chuck to machine, and please sufficiently understand and follow the instructions for safe operation.

## 8 . Attachment

### 8-1 Outline drawing of attachment

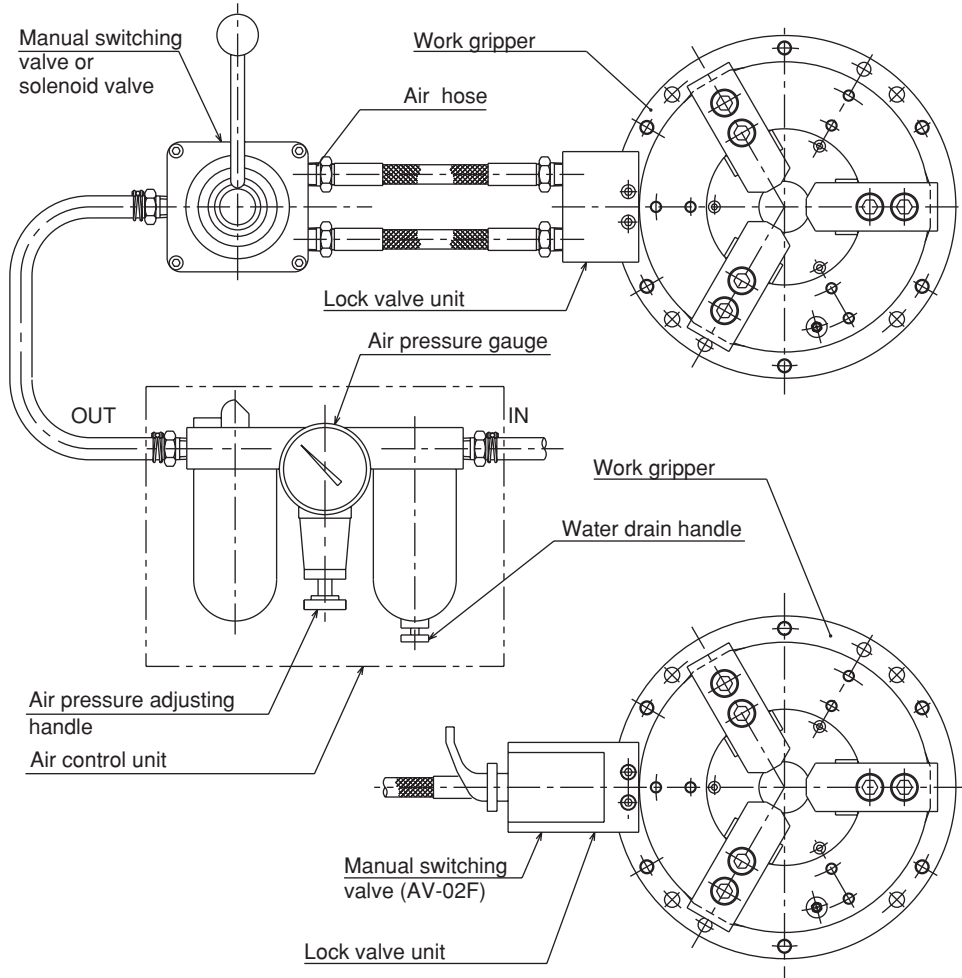

Fig. 17

### 8-2 Attachment of lock valve unit

Use a lock valve (safety valve, check valve) incorporated in case of sudden pneumatic pressure drop due to blackout, malfunction, etc. We prepare for the lock valve unit for exclusive use of the work gripper optionally.

#### Attaching procedures of lock valve unit

Read the following attaching procedures with reference to pages 5-7.

1. Loosen the cap screw [15] and Remove the block [12].
2. Confirm the O-ring [19] exists, and install the lock valve unit with the cap screw [59].

## 8-3 Attachment and piping of work gripper

- Connect the pipe to the air supply port at the block or work gripper bottom. Blind the port on the side not used.  
(Refer to Fig.19)
- To prevent the pressure drop and flow rate drop, use the pipe of Rc1/8 or larger size. Also, use the minimum number of elbows.
- Air control unit should be located near the work gripper as much as possible.
- Braided air hose should be used between the switching valve and the work gripper.

### **WARNING**

- Use a solenoid valve with a circuit that retains the gripping position when no current is carried. If the pneumatic pressure suddenly drops due to blackout or malfunction, etc., this is dangerous as work will fly out.
- During the piping, remove dust completely in the piping. Presence of dust in the piping causes air leakage and then the workpiece to fly out.

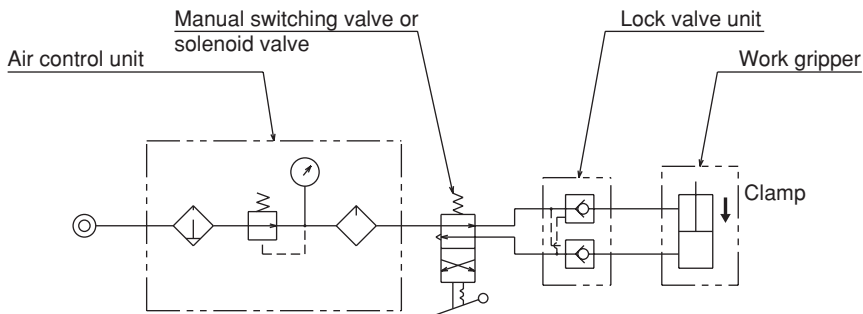

Fig. 18

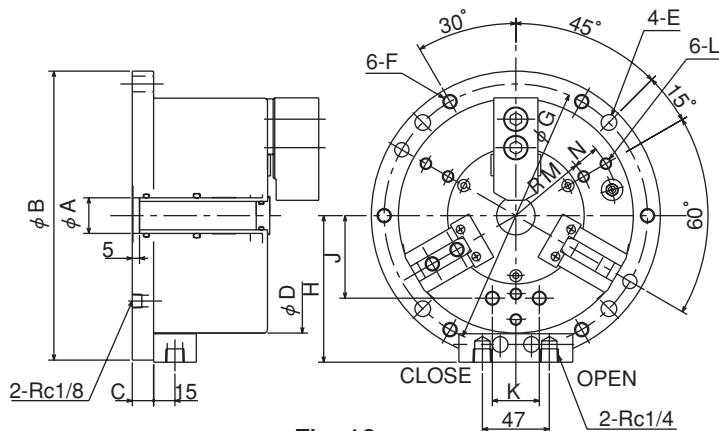

Fig. 19

Table 11

Dimension	AS04, AT04	AS06, AT06	AS08, AT08	AS10, AT10
$\phi$ A H7	20	25	36	50
$\phi$ B h7	148	203	248	300
C	15	15	15	16
$\phi$ D	110	165	210	254
$\phi$ E	9	11	11	13
F	M8	M10	M10	M12
$\phi$ G $\pm$ 0.2	130	185	230	280
H ※	75.5 (110.5)	103 (138)	125.5 (160.5)	147.5 (182.5)
J	29.7	58	78.3	93.6
K	33	33	33	33
L	—	M8	M8	M10
RM	—	55	68	85
N	—	18	25	30

※ Figures in parenthesis show when lock valve unit is installed

## 8-4 Attachment and piping of multi plate

It is convenient to use multi plates if you arrange and use a lot of work grippers. We prepare for the multi plate for exclusive use of the work gripper optionally.

### Attaching procedure

Read the following attaching procedures with reference to pages 5-7.

1. Prior to the installation, following the procedure in “9. Trial Operation” from page 30, check if each work gripper is normal. After check, close the jaws completely of the work gripper.
2. Loosen the jaw attaching bolt [13] and remove the soft jaw [8] and T-nut [9].
3. Loosen the cap screw [15] and remove the block [12].
4. Check the air hole position in the work gripper flange of the multi-plate, and install the work gripper with cap screws [83].
5. Confirm the O-ring [19] exists, and install the block [12] with the cap screw [15] to the multi plate surface. Moreover, it is also possible to install the special lock valve unit instead of the block [12].
6. Install the soft jaw [8] and T-nut [9] with the jaw attaching bolt [13].

### About piping

- Connect the universal elbow [78] to the air supply port at the bottom of work gripper, and connect a hard nylon air tube [79] between the elbow and the air supply port of multi-plate [71]. When connecting the universal elbow, wrap the seal tape around the elbow and check that the air does not leak.

#### CAUTION

- Use an eyebolt when attaching and detaching the chuck to and from the machine, as there is a danger of injury or damage if the work gripper drops.

Size	Eyebolt
4"	None
6"	M8
8"	M8
10"	M10

## 9 . Trial Operation

---

Thoroughly read the “Important Safety Precautions” on and after page 8 in this manual before trial operation.

1. Supply grease, following the “6-2.Grease lubrication” on and after page 23 in this manual.
2. Supply turbine oil of additive-free of Class 1 (Viscosity ISO: VG32 or the equivalent) up to the upper extreme end of the indication table of the lubricator of the air control unit.
3. Turn the air pressure adjusting handle and set it to the 0.20-0.25 MPa. Then, make inching of the switching valve, in order to check that the switching valve can operate normally.
4. Turn the needle on the upper part of the lubricator to adjust the drop the site dome. The proper number of drops is 2 or 3 drops per a clamp.
5. Increase the air pressure up to 0.5 MPa, and check to see if air dose not leak and if there is nothing abnormal.

# 10 . Other Information

## 10-1 About standards and orders

This product is based on the following standards or orders.

- Machinery directive : 2006/42/EC Annex I
- EN ISO 12100 : 2010
- EN1550 : 1997+A1 : 2008

## 10-2 Information about markings of product

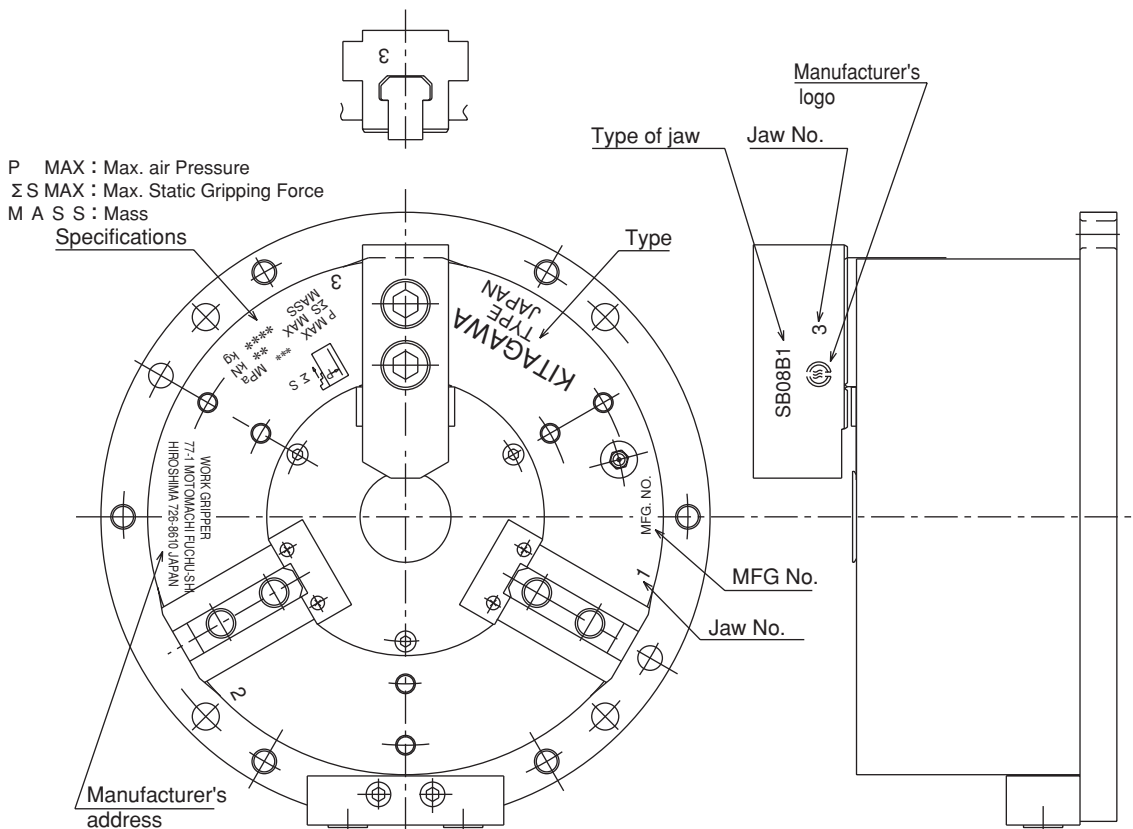

Fig. 20

## 10-3 About disposal

Ultimate disposal of this product should be handled according to all national laws and regulations.



## DECLARATION OF INCORPORATION

of partly completed machinery

Copy of original

We hereby declare that the following our product conform with the essential health and safety requirements of the EC Machinery Directive so that the product is to be incorporated into end-machinery. The product must not be put into service until end-machinery has been declared in conformity with the provisions of the EC Machinery Directive 2006/42/EC Annex II part 1.A.

We also declare that the specific technical documentation for this partly completed machinery was drawn up according to the EC Machinery Directive 2006/42/EC Annex VII part B.

Product	: Work gripper
Model	: AS / AT series (Models AS04, AS06, AS08, AS10, AT04, AT06, AT08, AT10)
Serial number	: See original declaration
Manufacturer	: Kitagawa Corporation 77-1, Motomachi, Fuchu-shi, Hiroshima 726-8610, Japan
Authorized compiler in the community	: Peter Soetebier / Prokurist Kitagawa Europe GmbH Borsigstr.3 D-40880 Ratingen, GERMANY

The essential health and safety requirements in accordance with the EC Machinery Directive 2006/42/EC Annex I were applied and fulfilled:  
1.1.2, 1.1.3, 1.1.5, 1.1.6, 1.3.1, 1.3.2, 1.3.4, 1.5.4, 1.5.8, 1.5.9, 1.5.13, 1.6.1, 1.7.1,  
1.7.2, 1.7.3, 1.7.4, 1.7.4.1, 1.7.4.2

The following harmonized standards were applied:  
EN ISO 12100:2010, EN 1550:1997+A1: 2008

Signature : See original declaration

Place / Date : See original declaration

Name / Title : Tomonari Hiromoto / Manager, Technical section 1  
Technical department  
Kitagawa Global hand Company

Being the responsible person appointed and employed the manufacturer.

## UK DECLARATION OF INCORPORATION

of partly completed machinery

Copy of original

We hereby declare that the following our product conform with the essential health and safety requirements of the Supply of Machinery (Safety) Regulations 2008 so that the product is to be incorporated into end-machinery. The product must not be put into service until end-machinery has been declared in conformity with the provisions of the Supply of Machinery (Safety) Regulations 2008 Annex II part 1.A.

We also declare that the specific technical documentation for this partly completed machinery was drawn up according to the Supply of Machinery (Safety) Regulations 2008 Annex VII part B.

Product	: Work gripper
Model	: AS / AT series (Models AS04, AS06, AS08, AS10, AT04, AT06, AT08, AT10)
Serial number	: See original declaration
Manufacturer	: Kitagawa Corporation 77-1, Motomachi, Fuchu-shi, Hiroshima 726-8610, Japan
Authorized complier in the community	: Mark Jones / Financial Director UNIT 1 THE HEADLANS, DOWNTON, SALISBURY, WILTSHIRE, SP5 3JJ, UNITED KINGDOM

The essential health and safety requirements in accordance with the Supply of Machinery (Safety) Regulations 2008 Annex I were applied and fulfilled:  
1.1.2, 1.1.3, 1.1.5, 1.1.6, 1.3.1, 1.3.2, 1.3.4, 1.5.4, 1.5.8, 1.5.9, 1.5.13, 1.6.1, 1.7.1,  
1.7.2, 1.7.3, 1.7.4, 1.7.4.1, 1.7.4.2

The following harmonized standards were applied:  
EN ISO 12100:2010, EN 1550:1997+A1: 2008

Signature : See original declaration

Place / Date : See original declaration

Name / Title : Tomonari Hiromoto / Manager, Technical section 1  
Technical department  
Kitagawa Global hand Company

Being the responsible person appointed and employed the manufacturer.



**Kitagawa Corporation Kitagawa Global hand Company**

77-1, Motomachi, Fuchu-shi, Hiroshima, 726-8610, Japan

Tel. +81-847-40-0561

Fax. +81-847-45-8911

■ JAPAN DOMESTIC

<b>Tokyo office</b>	1-405-1, Kita-ku, Yosino-cho, Saitama-shi, Saitama, 331-9634, Japan Tel. +81-48-667-3469 Fax. +81-48-663-4678
<b>Sendai office</b>	4-15-13, Yamatomachi, Wakabayashi-ku, Sendai-shi, Miyagi, 984-0042, Japan Tel. +81-22-232-6732 Fax. +81-22-232-6739
<b>Nagoya office</b>	2-62, Kamitakabata, Nakagawa-ku, Nagoya-shi, Aichi, 454-0873, Japan Tel. +81-52-363-0371 Fax. +81-52-362-0690
<b>Osaka office</b>	3-2-9, Kitagagaya, Suminoe-ku, Osaka-shi, Osaka, 559-0011, Japan Tel. +81-6-6685-9065 Fax. +81-6-6684-2025
<b>Hiroshima office</b>	77-1, Motomachi, Fuchu-shi, Hiroshima, 726-8610, Japan Tel. +81-847-40-0541 Fax. +81-847-46-1721
<b>Kyushu office</b>	7-6-39, Itazuke, Hakata-ku, Fukuoka-shi, Fukuoka, 812-0888, Japan Tel. +81-92-501-2102 Fax. +81-92-501-2103
<b>Overseas office</b>	77-1, Motomachi, Fuchu-shi, Hiroshima, 726-8610, Japan Tel. +81-847-40-0526 Fax. +81-847-45-8911

■ OVERSEAS

<b>America Contact</b>	<b>KITAGAWA-NORTHTECH INC.</b> 301 E. Commerce Dr, Schaumburg, IL. 60173 USA Tel. +1 847-310-8787 Fax. +1 847-310-9484	<a href="https://www.kitagawa-usa.com">https://www.kitagawa-usa.com</a>
<b>Europe Contact</b>	<b>KITAGAWA EUROPE LTD.</b> Unit 1 The Headlands, Downton, Salisbury, Wiltshire SP5 3JJ, United Kingdom Tel. +44 1725-514000 Fax. +44 1725-514001	<a href="https://www.kitagawa.global/en">https://www.kitagawa.global/en</a>
	<b>KITAGAWA EUROPE GmbH</b> Borsigstrasse 3, 40880, Ratingen Germany Tel. +49 2102-123-78-00 Fax. +49 2102-123-78-69	<a href="https://www.kitagawa.global/de">https://www.kitagawa.global/de</a>
	<b>KITAGAWA EUROPE GmbH Poland Office</b> 44-240 Zory, ul. Niepodleglosci 3 Poland Tel. +48 607-39-8855	<a href="https://www.kitagawa.global/pl">https://www.kitagawa.global/pl</a>
	<b>KITAGAWA EUROPE GmbH Czech Office</b> Purkynova 125, 612 00 Brno, Czech Republic Tel. +420 603-856-122	<a href="https://www.kitagawa.global/cz">https://www.kitagawa.global/cz</a>
	<b>KITAGAWA EUROPE GmbH Romania Office</b> Strada Heliului 15, Bucharest 1, 013991, Romania Tel. +40 727-770-329	<a href="https://www.kitagawa.global/ro">https://www.kitagawa.global/ro</a>
	<b>KITAGAWA EUROPE GmbH Hungary Office</b> Dery T.u.5, H-9024 Győr, Hungary Tel. +36 30-510-3550	<a href="https://www.kitagawa.global/hu">https://www.kitagawa.global/hu</a>
<b>Asia Contact</b>	<b>KITAGAWA INDIA PVT LTD.</b> Plot No.42, 2nd Phase Jigani Industrial Area, Jigani, Bangalore – 560105, Karnataka, India Tel. +91-80-2976-5200 Fax. +91-80-2976-5205	<a href="https://www.kitagawa.global/in">https://www.kitagawa.global/in</a>
	<b>KITAGAWA (THAILAND) CO., LTD. Bangkok Branch</b> 9th FL, Home Place Office Building, 283/43 Sukhumvit 55 Rd. (Thonglor 13), Klongton-Nua, Wattana, Bangkok 10110, Thailand Tel. +66 2-712-7479 Fax. +66 2-712-7481	
	<b>Kitagawa Corporation (Shanghai)</b> Room 308 3F Building B. Far East International Plaza, No. 317 Xian Xia Road, Chang Ning, Shanghai, 200051, China Tel. +86 21-6295-5772 Fax. +86 21-6295-5792	<a href="https://www.kitagawa.com.cn">https://www.kitagawa.com.cn</a>
	<b>Kitagawa Corporation (Shanghai) Guangzhou Office</b> B07, 25/F, West Tower, Yangcheng International Trading Centre, No. 122, East Tiyu Road, Tianhe District, Guangzhou, China Tel. +86 20-2885-5276	
	<b>DEAMARK LIMITED</b> No. 6, Lane 5, Lin Sen North Road, Taipei, Taiwan Tel. +886 2-2393-1221 Fax. +886 2-2395-1231	<a href="http://www.deamark.com.tw">http://www.deamark.com.tw</a>
<b>KITAGAWA KOREA AGENT CO., LTD.</b> 803 Ho, B-Dong, Woolim Lion's Valley, 371-28 Gasan-Dong, Gumcheon-Gu, Seoul, Korea Tel. +82 2-2026-2222 Fax. +82 2-2026-2113	<a href="http://www.kitagawa.co.kr">http://www.kitagawa.co.kr</a>	
<b>Oceania Contact</b>	<b>DIMAC TOOLING PTY. LTD.</b> 69-71 Williams Rd, Dandenong South, Victoria, 3175 Australia Tel. +61 3-9561-6155 Fax. +61 3-9561-6705	<a href="https://www.dimac.com.au">https://www.dimac.com.au</a>

The products herein are controlled under Japanese Foreign Exchange and Foreign Trade Control Act. In the event of importing and/or exporting the products, you are obliged to consult KITAGAWA as well as your government for the related regulation prior to any transaction.