



WORK GRIPPER

スクロールワークグリッパ

SC-S series

安心、安定、使い易い ステーションナリスクロールチャック

- 複数セッティングでも個々の位置設定は自在
- 狭いスペースにもセッティング可能
- 多様なワークに対応できる、爪分割式のソフトジョー仕様
- 使い易い専用ハンドル付

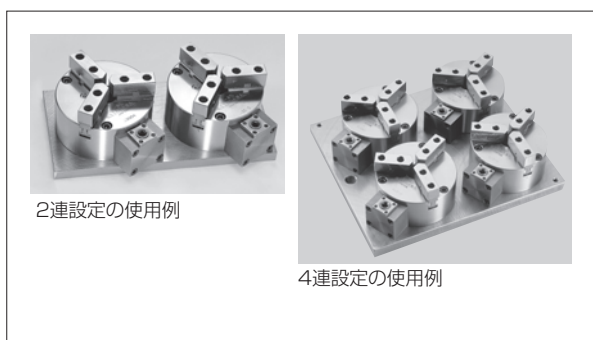

■ 寸法図

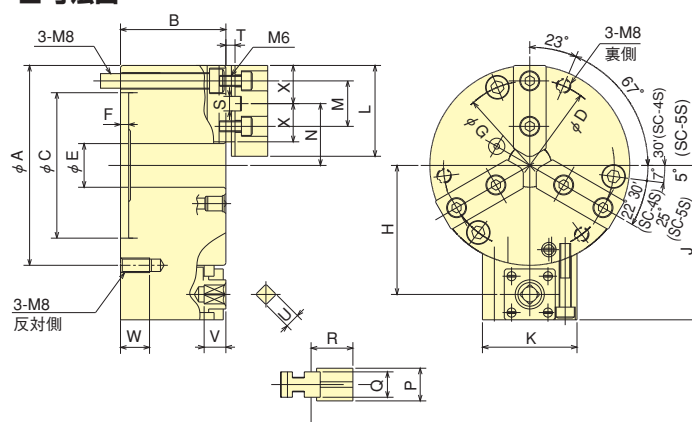

■ 仕様表 ※把握径/把握範囲は標準のソフトジョーを使用した場合。

| 型式 | 仕様 | 最大静的把握力 kN | 許容ハンドルトルク N・m | 質量 kg | 把握範囲 | |
|-------|----|---------------|------------------|----------|------------|------------|
| | | | | | 外径 φ mm | 内径 φ mm |
| SC-4S | | 9.6 | 27.5 | 4.0 | 3~95 | 29~84 |
| SC-5S | | 12.0 | 39.2 | 5.3 | 3~110 | 33~100 |

■ 寸法表

| 型式 | 寸法 | | | | | | | | | | | | | | | | | | | | | | |
|-------|-----|----|--------|-----|----|-----|-----|----|----|----|----|----|------|------|----|----|----|---|---|---|----|----|----|
| | A | B | C (H6) | D | E | F | G | H | J | K | L | M | Nmin | Nmax | P | Q | R | S | T | U | V | W | X |
| SC-4S | 110 | 58 | 80 | 95 | 24 | 4.5 | 93 | 71 | 85 | 52 | 50 | 25 | 26 | 37 | 18 | 14 | 23 | 8 | 5 | 8 | 12 | 16 | 21 |
| SC-5S | 130 | 60 | 100 | 115 | 32 | 4.5 | 113 | 81 | 95 | 56 | 60 | 30 | 30 | 45 | 20 | 16 | 26 | 8 | 6 | 8 | 12 | 16 | 25 |

■ ソフトジョー寸法図

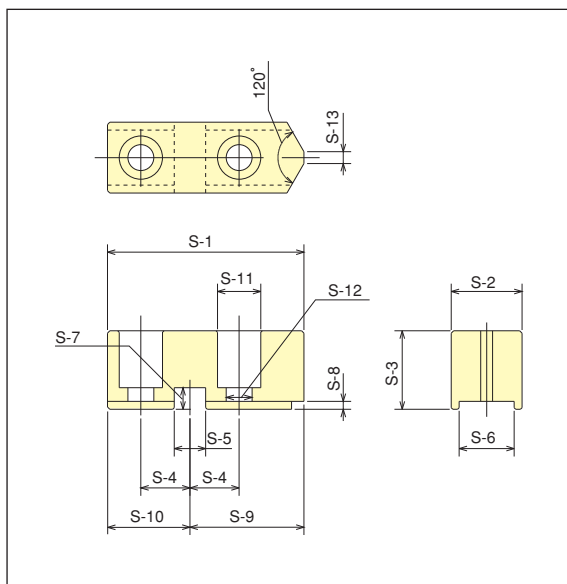

■ ソフトジョー寸法表

| 型式 | 寸法 | チャック サイズ | ソフトジョー寸法 | | | | | | |
|--------|----|-------------|----------|-----|-----|-------------|-------------------|-----------------------|--|
| | | | S-1 | S-2 | S-3 | S-4 ±0.1 | S-5 +0.01 0 | S-6 +0.05 +0.02 | |
| SBS04S | | 4 | 50 | 18 | 20 | 12.5 | 8 | 14 | |
| SBS05S | | 5 | 60 | 20 | 22 | 15 | 8 | 16 | |

| 型式 | 寸法 | ソフトジョー寸法 | | | | | | |
|--------|----|----------|-----|-----|------|------|------|------|
| | | S-7 | S-8 | S-9 | S-10 | S-11 | S-12 | S-13 |
| SBS04S | | 5.5 | 2 | 29 | 21 | 11 | 6.6 | 3 |
| SBS05S | | 5.5 | 2 | 35 | 25 | 11 | 6.6 | 3 |

■ ハンドル寸法図

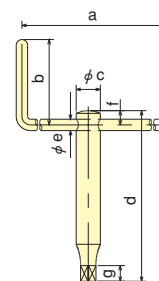

■ ハンドル寸法表

| 型式 | 寸法 | | | | | | |
|-------|-----|----|----|-----|----|----|----|
| | a | b | c | d | e | f | g |
| SC-4S | 130 | 60 | 17 | 120 | 8 | 10 | 11 |
| SC-5S | 150 | 60 | 20 | 130 | 10 | 12 | 11 |



WORK GRIPPER

Stationary Scroll Chuck

SC-S series

Durable, reliable and versatile Stationary scroll chuck

- Available on multiplate for easy fixture mounting
- Compact designed
- Soft jaw can be machined to adapt to a wide range of machine work-pieces
- Uses exclusive handle for clamping



2 chuck fixture sample



4 chuck fixture sample

Dimensional Drawings

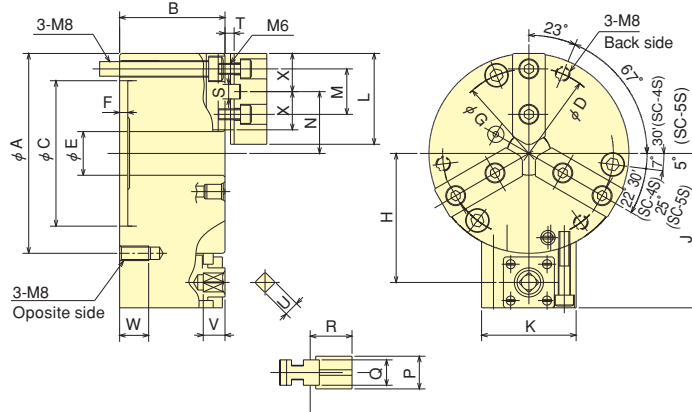

Specifications ※Gripping dia./gripping range is with standard soft jaws.

| Model | Specifications | Max. Gripping Force kN | Allowable handle torque N·m | Net Weight kg | Gripping range | |
|-------|----------------|---------------------------|--------------------------------|------------------|--------------------|--------------------|
| | | | | | external ϕ mm | internal ϕ mm |
| SC-4S | | 9.6 | 27.5 | 4.0 | 3~95 | 29~84 |
| SC-5S | | 12.0 | 39.2 | 5.3 | 3~110 | 33~100 |

Dimensions

| Model | A | B | C (H6) | D | E | F | G | H | J | K | L | M | Nmin | Nmax | P | Q | R | S | T | U | V | W | X |
|-------|-----|----|--------|-----|----|-----|-----|----|----|----|----|----|------|------|----|----|----|---|---|---|----|----|----|
| SC-4S | 110 | 58 | 80 | 95 | 24 | 4.5 | 93 | 71 | 85 | 52 | 50 | 25 | 26 | 37 | 18 | 14 | 23 | 8 | 5 | 8 | 12 | 16 | 21 |
| SC-5S | 130 | 60 | 100 | 115 | 32 | 4.5 | 113 | 81 | 95 | 56 | 60 | 30 | 30 | 45 | 20 | 16 | 26 | 8 | 6 | 8 | 12 | 16 | 25 |

Dimensional Drawings for Soft Jaw

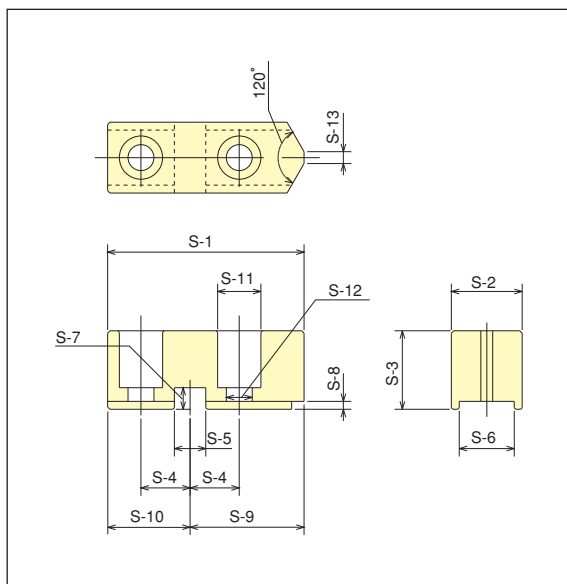

Dimensions for Soft Jaws

| Model | Dimensions | chuck size | S-1 | S-2 | S-3 | S-4 ± 0.1 | S-5 $+0.01/0$ | S-6 $+0.05/+0.02$ |
|--------|------------|------------|-----|-----|-----|---------------|---------------|-------------------|
| SBS04S | | 4 | 50 | 18 | 20 | 12.5 | 8 | 14 |
| SBS05S | | 5 | 60 | 20 | 22 | 15 | 8 | 16 |

| Model | Dimensions | S-7 | S-8 | S-9 | S-10 | S-11 | S-12 | S-13 |
|--------|------------|-----|-----|-----|------|------|------|------|
| SBS04S | | 5.5 | 2 | 29 | 21 | 11 | 6.6 | 3 |
| SBS05S | | 5.5 | 2 | 35 | 25 | 11 | 6.6 | 3 |

Dimensional Drawings for Handle

Dimensions for Handles

| Model | a | b | c | d | e | f | g |
|-------|-----|----|----|-----|----|----|----|
| SC-4S | 130 | 60 | 17 | 120 | 8 | 10 | 11 |
| SC-5S | 150 | 60 | 20 | 130 | 10 | 12 | 11 |

