

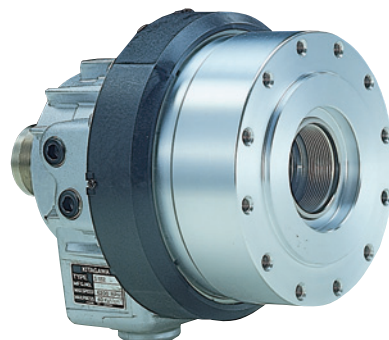

ROTARY CYLINDER

中空回転油圧シリンダ (ロングストローク) Hydraulic Cylinder with Through-Hole and Long Stroke S-L series

中空のKITAGAWAスタンダードタイプ KITAGAWA standard thru-hole type



- ロングストロークタイプ
Long piston stroke
- ロックバルブ、リリーフバルブ内蔵
Built-in check valve and relief valve
- クーラントコレクタや確認装置がオプションで選択可能
Coolant collector and confirmation devices are available as an option

※オプションについてはP76を参照してください。
※Please refer to P76 about options.

*CE対応品 (確認装置付のみ)
*CE correspondence (Only series with confirmation device)

■ 寸法図 Dimensional Drawings

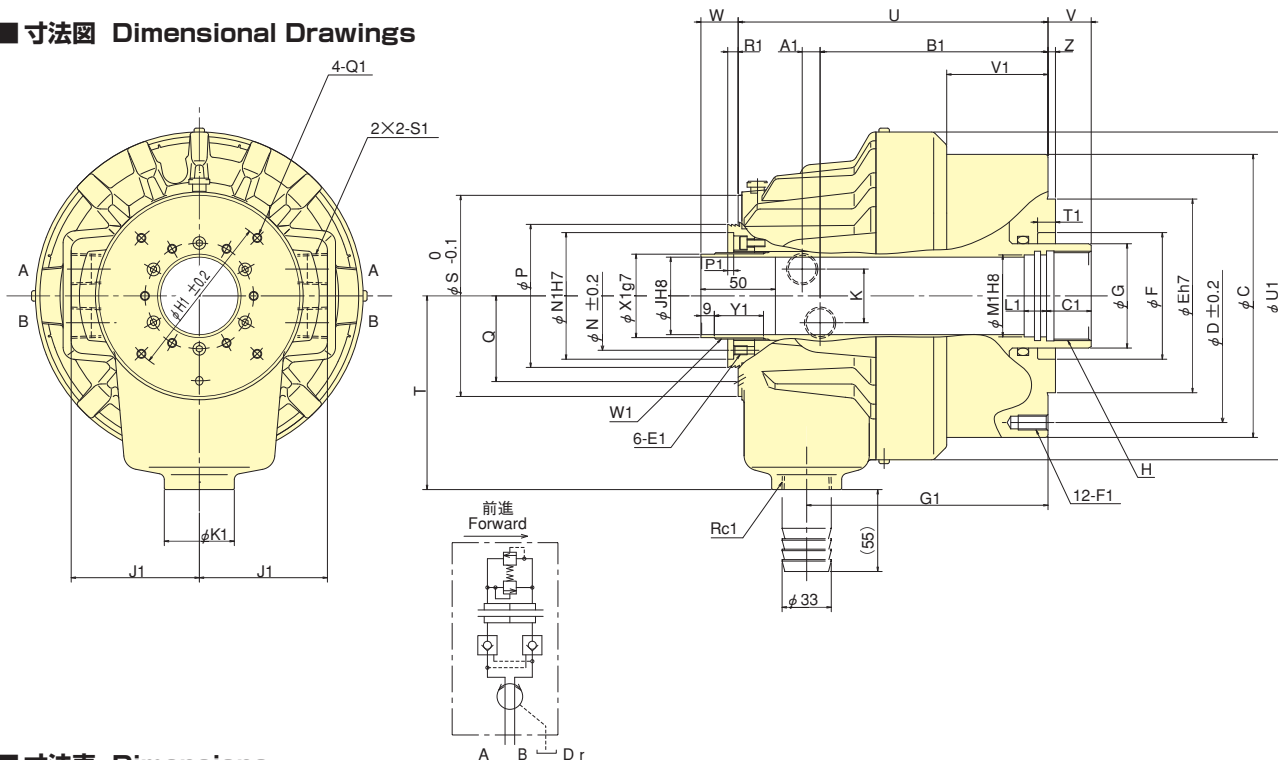

■ 寸法表 Dimensions

寸法 Dimensions Model	C	D	E	F	G	H	J 貫通穴 Thru-Hole	K	N	P	Q	S	T	U	V max.	V min.	W max.	W min.	Z	A ₁	B ₁
S1246L	155	130	100	80	65	M55×2.0	46	36	64	85	51.5	119.5	115	200	27	-5	57	25	5	11.5	147.5
S1552L	190	170	130	85	70	M60×2.0	52	36	73	96	57.5	139.5	130	208	29	-5	59	25	5	12	153
S1875L	215	190	160	120	95	M85×2.0	75	36	98	121	70.5	168	160	241	35	-5	65	25	5	17.5	169.5
S2091L	240	215	180	140	110	M100×2.0	91	34	108	138	79	183.5	185	268	45	-5	75	25	5	21	188

寸法 Dimensions Model	C ₁	E ₁ 深さ depth	F ₁ 深さ depth	G ₁	H ₁	J ₁	K ₁	L ₁	M ₁	N ₁	P ₁	Q ₁ 深さ depth	R ₁	S ₁	T ₁	U ₁	V ₁	W ₁	X ₁	Y ₁
S1246L	30	M6×9	M10×20	156	98	76	47	15	50	76	4	M5×10	6	Rc1/2	12	200	67	M52×1.5	50	33
S1552L	30	M6×9	M10×20	162	110	86	47	15	55	85	4	M6×12	7	Rc1/2	12	220	68	M58×1.5	56	33
S1875L	35	M6×9	M10×20	182.5	155	101	47	15	80	108	4	M6×12	7	Rc1/2	12	242	74	M84×2.0	81	33
S2091L	35	M6×14	M12×24	203	165	110	47	15	95	120	4	M6×12	7	Rc1/2	12	267	86	M99×2.0	96	38

■ 仕様表 Specifications

※ドレン量：油圧力3.0MPa、油温50℃の時 ※ピストン推力：油圧力4.0MPa
 ※Leakage: Pressure 3.0MPa and oil temperature 50℃. ※Piston thrust: Pressure 4.0MPa

仕様 Specifications Model	ピストンストローク Piston stroke mm	ピストン表面積 Piston Area cm ²	ピストン推力 Piston thrust kN	最高使用油圧力 Max. Operation Pressure MPa	許容最高回転速度 Max. Speed min ⁻¹	慣性モーメント Moment of inertia kg·m ²	質量 Net Weight kg	ドレン量 Leakage ℓ/min
S1246L	32	100	38.0	4.0	7000	0.022	12.8	3.0
S1552L	34	161	60.0	4.0	6200	0.058	17.0	3.9
S1875L	40	198	74.0	4.0	4700	0.100	26.8	4.2
S2091L	50	252	94.0	4.0	3800	0.160	34.1	4.5

回転油圧
Cylinder