



CHUCK

分割爪スクロールチャック (ショートテーパ) Scroll Chuck with 2 Piece Jaw (Direct Mount) JN-RA series

用途に応じてジョーの使い分けが可能 Two piece jaw

●ショートテーパ Short taper

アダプタなしで直接取り付けできるショートテーパ用チャック。本体は軽量で継ぎ目のない高剛性ソリッドボデー。

Direct mount to short taper without the need for separate adaptor.

●ソフトジョー(オプション) Soft jaw (option)

ハードジョーが標準付属。ソフトジョーも使用可能。(オプション、JN-Tタイプと兼用)

Supplied with standard hard jaws (fitted). Soft jaw can also be used. (Option, used together with JN-T type)



■寸法図 Dimensional Drawings

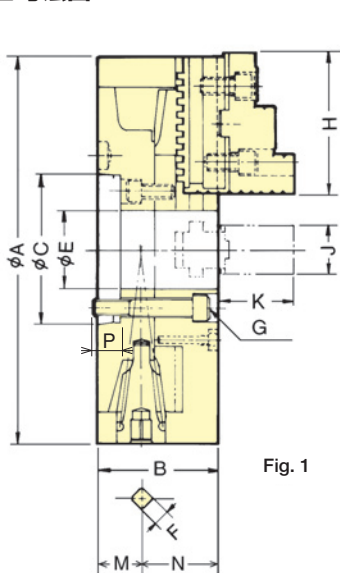

Fig. 1

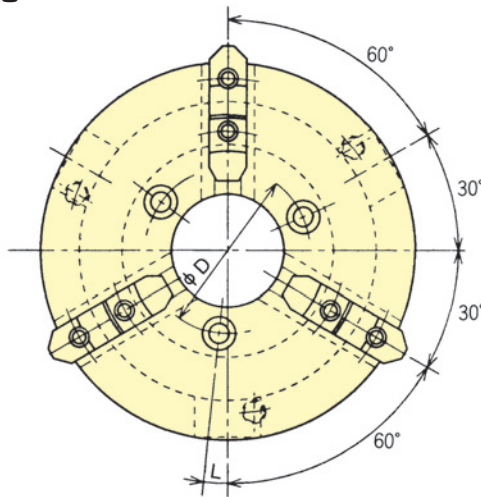
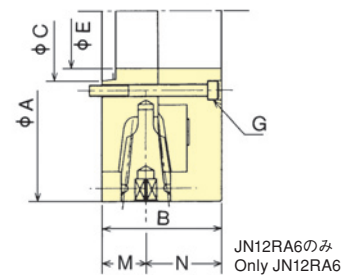

Fig. 2



JN12RA6のみ
Only JN12RA6

■寸法表 Dimensions

型式 Type	寸法 Size	A	B	C	D	E	F	G	H	J	K	L	M	N	P
JN06RA5		165	65.5	82.563	61.9	40	10	3-M10	68	26	39	6°	24	41	16
JN07RA5		190	75	82.563	61.9	40	11	3-M10	80	28	42	5°	27.5	47.5	16.5
JN08RA6		210	75	106.375	82.6	59	11	3-M12	80	28	42	6°	29	46	15.5
JN09RA6		232	84	106.375	82.6	59	12	3-M12	90	32	50	6°	29.5	54.5	16.5
JN10RA6		273	86	106.375	82.6	59	12	3-M12	100	35	54	0°	31.5	54.5	14.5
JN10RA8		273	86	139.719	111.1	78	12	3-M16	100	35	54	15°	31.5	54.5	18.5
JN12RA6		310	96	106.375	133.4	96	14	3-M12	115	40	56	0°	31.5	64.5	18.5
JN12RA8		310	96	139.719	111.1	78	14	3-M16	115	40	56	0°	31.5	64.5	23.5

■仕様表 Specifications ※把握径/把握範囲は標準のハードジョーを使用した場合。*Gripping dia./gripping range is with standard hard jaws.

型式 Type	仕様 Spec. Thru-Hole mm	最大静的把握力 Max. Gripping Force kN	許容最高回転速度 Max. Speed min ⁻¹	質量 Net Weight kg	慣性モーメント Moment of inertia kg·m ²	把握範囲 Gripping range		適合ハードジョー Matching Hard top jaw	ハンドトルク Handle torque N·m
						外径 external φ mm	内径 internal φ mm		
JN06RA5	40	31.0	4000	9.3	0.035	3~160	55~150	HBS06C	88.3
JN07RA5	40	31.0	3500	13.4	0.068	4~180	62~170	HBS07C	107.9
JN08RA6	59	31.0	3200	18.0	0.103	4~200	62~190	HBS07C	107.9
JN09RA6	59	37.0	2900	23.5	0.170	5~220	70~210	HBS09C	147.0
JN10RA6	59	46.0	2500	30.5	0.275	5~260	80~250	HBS10C	176.5
JN10RA8	78	46.0	2500	31.0	0.280	5~260	80~250	HBS10C	176.5
JN12RA6	96	55.0	2200	44.0	0.595	10~300	90~290	HBS12C	206.0
JN12RA8	78	55.0	2200	45.0	0.608	10~300	90~290	HBS12C	206.0