



**CHUCK**

# スクロールチャックのパーツ ご注文に際して

## ●スクロールチャックのハードジョー(内・外・分割(上爪/下爪))ご注文に際して

- ・SC series … 3・4・5・14・16インチのボデーは鋳鉄製。  
JN / JN-T JN-RA series … 6~12インチのボデーはスチール製。

SCシリーズは、チャックボデーにジョー嵌め合部のアリ溝を現物合わせし、ワーク把握面を含み研磨を実施しています。原則チャックをお預かりし、修理として芯研磨を実施いたします。

JNシリーズは、芯研磨はジョーの把握面の部位となります。

分割爪チャック(JN-T / JN-RA)の下爪(爪受け台)の場合、SCシリーズと同様チャック本体のアリ溝部の現物合わせが必要となります。

しかし、お客様の強いご要望によりパーツのみの出荷も対応しますが、上記内容により本体にジョーが挿入できない等、お客様ご使用のチャックに対して合わせ研磨を実施していないために精度不良が生じる場合があります。

お客様納入後による返品は、原則お引き受けできませんのでご注意ください。

### ■ハードジョー (SC series)

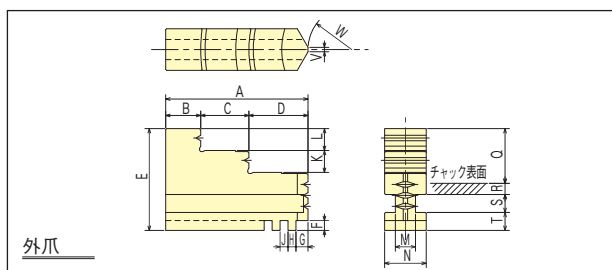
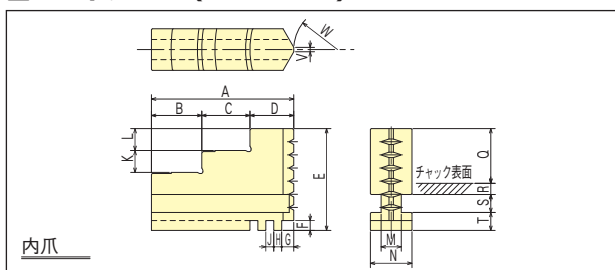

### ■SC series ジョー寸法表

チャック型式		A	B	C	D	E	F	G	H	J	K	L	M	N	Q	R	S	T	V	W
SC-3	内爪	35	14	10	11	29	2.5	4	2.11	2.11	6	6	5.7	11	15	2.75	6.55	4.7	1	R 7.5
	外爪	35	9	10	16	29	2.5	4	2.11	2.11	6	6	5.7	11	15	2.75	6.55	4.7	1	R 7.5
SC-4	内爪	42	16	13	13	34.5	3.5	4.5	2.54	2.54	7	7	7.2	14	18	3.75	6.55	6.2	1.5	R11
	外爪	42	10	13	19	34.5	3.5	4.5	2.54	2.54	7	7	7.2	14	18	3.75	6.55	6.2	1.5	R11
SC-5	内爪	50	20	15	15	40	4	4	3.175	3.175	8	8	7.2	16	20	4.1	8.2	7.7	1.5	R15
	外爪	50	14	15	21	40	4	4	3.175	3.175	8	8	7.2	16	20	4.1	8.2	7.7	1.5	R15
SC-14	内爪	132	49	42	41	93.5	7	8	5.08	5.08	18	18	19	35	52	9.3	16.2	16	5	R47
	外爪	132	40	41	51	93.5	7	8	5.08	5.08	18	18	19	35	52	9.3	16.2	16	5	R47
SC-16	内爪	146	52	50	44	102	7	10.5	5.08	5.08	20	20	23	40	58	11.8	16.2	16	6	R53
	外爪	146	43	50	53	102	7	10.5	5.08	5.08	20	20	23	40	58	11.8	16.2	16	6	R53

### ■ハードジョー (JN series)

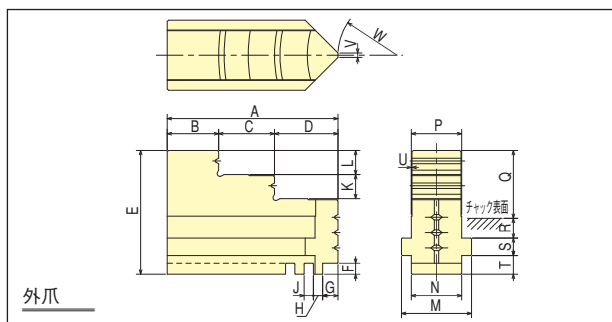
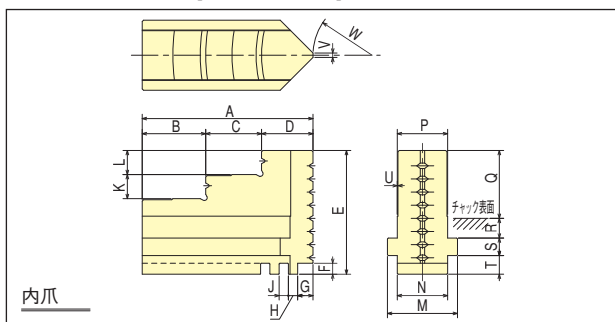

### ■JN series ジョー寸法表

チャック型式		A	B	C	D	E	F	G	H	J	K	L	M	N	P	Q	R	S	T	U	V	W
JN06	内爪	66	26.5	19	20.5	48.5	4.5	5.5	3.629	3.629	9	9	29	21	21	27	8	6.5	7	0.3	2	R19.5
	外爪	66	18	19	29	48.5	4.5	5.5	3.629	3.629	9	9	29	21	21	27	8	6.5	7	0.3	2	R19.5
JN07	内爪	78	29	25.5	23.5	56.5	5	7	4.233	4.233	11	11	32	23	23	31	9	8	8.5	0.3	2	R27
	外爪	78	20.5	25.5	32	56.5	5	7	4.233	4.233	11	11	32	23	23	31	9	8	8.5	0.3	2	R27
JN09	内爪	88	34	28	26	62.5	5	7.5	4.233	4.233	13	13	38	27	27	33	10.5	9.5	9.5	0.3	3	R34.5
	外爪	88	24	28	36	62.5	5	7.5	4.233	4.233	13	13	38	27	27	33	10.5	9.5	9.5	0.3	3	R34.5
JN10	内爪	98	36.5	32	29.5	66.5	5	7.5	4.233	4.233	14	14	38	27	27	37	10.5	9.5	9.5	0.3	3	R42
	外爪	98	28	32	38	66.5	5	7.5	4.233	4.233	14	14	38	27	27	37	10.5	9.5	9.5	0.3	3	R42
JN12	内爪	113	41.5	36.5	35	81	6	8	5.08	5.08	15	15	44	31	31	44	14.5	11	11	0.3	4	R42
	外爪	113	33	36.5	43.5	81	6	8	5.08	5.08	15	15	44	31	31	44	14.5	11	11	0.3	4	R42

特殊・NC型  
 Jaws and Accessories

■ JN・JN-T・JN-RA把握範囲表

型式	把握範囲							
	外径把握					内径把握		
	A1	A2	A3	A4	ソフトジョー	B1	B2	ソフトジョー
SC-3(F)	2~35	33~55	53~70	2~35	(2~70)	24~44	42~64	(24~64)
SC-4(F)	3~43	41~69	67~95	3~43	(3~95)	29~57	55~84	(29~84)
SC-5(F)	3~46	44~77	75~110	3~46	(3~110)	33~67	65~100	(33~100)
JN06	3~64	62~112	110~160	3~64	-	48~100	98~150	-
JN06T	3~64	62~112	110~160	-	3~160	55~104	102~150	55~150
JN06R	3~64	62~112	110~160	-	-	55~104	102~150	-
JN07	4~72	70~126	124~180	4~72	-	56~114	112~170	-
JN07T	4~68	66~124	122~180	-	4~180	62~117	115~170	62~170
JN07R	4~68	66~124	122~180	-	-	62~117	115~170	-
JS07	4~72	70~126	124~180	4~72	-	56~114	112~170	-
JT07	-	-	-	-	4~180	-	-	62~170
JN08R	4~76	74~138	136~200	-	-	62~127	125~190	-
JN09	5~84	82~150	150~220	5~84	-	62~137	135~210	-
JN09T	5~80	78~150	148~220	-	5~220	70~141	139~210	70~210
JN09R	5~80	78~150	148~220	-	-	70~141	139~210	-
JS09	5~84	82~152	150~220	5~84	-	62~137	135~210	-
JT09	-	-	-	-	5~220	-	-	70~210
JN10	5~96	94~178	176~260	5~96	-	70~161	159~250	-
JN10T	5~94	92~177	176~260	-	5~260	80~166	164~250	80~250
JN10R	5~94	92~177	176~260	-	-	80~166	164~250	-
JN12	10~108	108~204	202~300	10~108	-	86~189	187~290	-
JN12T	10~108	108~204	202~300	-	10~300	90~191	189~290	90~290
JN12R	10~108	108~204	202~300	-	-	90~191	189~290	-
SC-14	25~118	116~210	208~315	25~118	-	107~188	186~290	-
SC-16	25~132	130~215	213~360	25~132	-	113~212	210~340	-

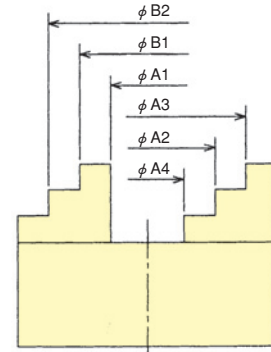

SC(F)/JN/JS type

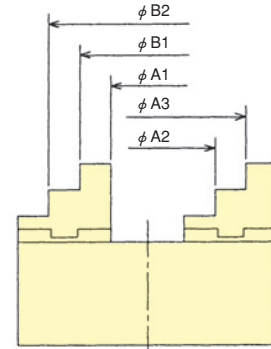

JN-T/JN-R type

■ チャックハンドル寸法表

型式	F1	F2	F3	F4	F5
SC-3	65	15	8	110	7
SC-4	70	17	8	140	8
SC-5	75	20	10	170	8
JN06	120	20	10	210	10
JN07	160	20	12	240	11
JN09	160	22	12	290	12
JN10	160	22	12	360	12
JN12	200	26	16	390	14
SC-14	140	30	16	450	15
SC-16	140	30	16	450	15
IC-4	75	12	8	120	6
IC-6	100	13	8	150	8
IC-8	130	15	10	200	10
IC-10	150	18	12	250	10
IC-12	170	19	12	300	12
IC-14	170	19	12	300	12
IC-16	220	22	16	400	14
IC-18	220	22	16	400	14

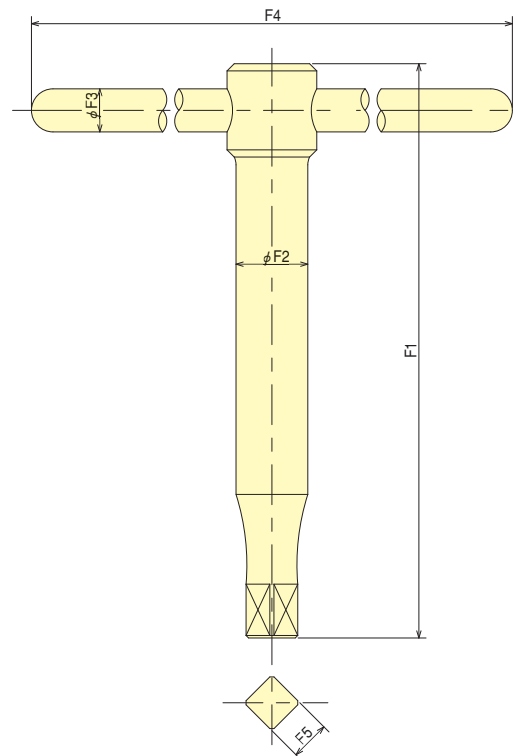



**CHUCK**

# For order of Scroll Chuck parts

● For order of hard jaws of scroll chuck [Internal, External & 2 piece jaw (Top and Base jaws)]

- SC series ... Bodies of 3, 4, 5, 14 and 16 inches are made of cast iron.
- JN / JN-T JN-RA series ... Bodies of 12 -16 inches are made of steel.

In SC series, Hard jaws are ground with the chuck and it is required the tolerance combination on the jaw fitting. As a general rule, Gripping face is ground concentrically in our shop as repair.

In JN series, the tolerance combination is not required but Gripping face is need to be ground concentrically.

In case of Base jaw for the 2 piece jaw chucks(JN-T/JN-RA), the tolerance combination is also required as well as SC type chucks.

At customer's strong demand, only parts will be supplied however, problem may occur, i.e. Accuracy is not satisfied because jaws are not ground with the existing chuck body.

## ■ Hard Jaw (SC series)

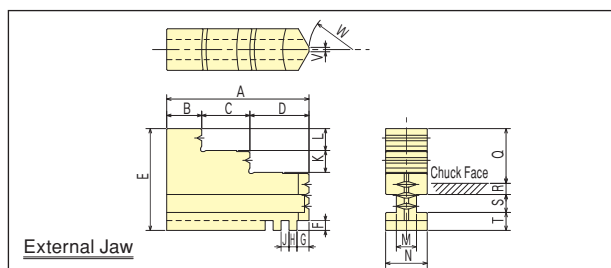
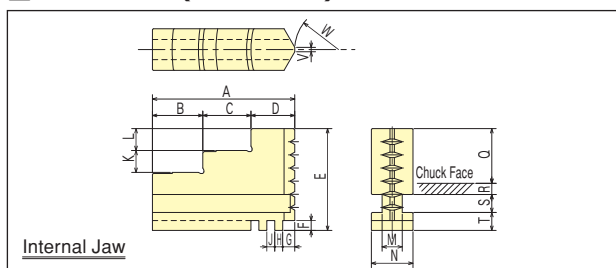

## ■ SC series Jaw Dimensions

Model		A	B	C	D	E	F	G	H	J	K	L	M	N	Q	R	S	T	V	W
SC-3	Internal jaw	35	14	10	11	29	2.5	4	2.11	2.11	6	6	5.7	11	15	2.75	6.55	4.7	1	R 7.5
	External jaw	35	9	10	16	29	2.5	4	2.11	2.11	6	6	5.7	11	15	2.75	6.55	4.7	1	R 7.5
SC-4	Internal jaw	42	16	13	13	34.5	3.5	4.5	2.54	2.54	7	7	7.2	14	18	3.75	6.55	6.2	1.5	R11
	External jaw	42	10	13	19	34.5	3.5	4.5	2.54	2.54	7	7	7.2	14	18	3.75	6.55	6.2	1.5	R11
SC-5	Internal jaw	50	20	15	15	40	4	4	3.175	3.175	8	8	7.2	16	20	4.1	8.2	7.7	1.5	R15
	External jaw	50	14	15	21	40	4	4	3.175	3.175	8	8	7.2	16	20	4.1	8.2	7.7	1.5	R15
SC-14	Internal jaw	132	49	42	41	93.5	7	8	5.08	5.08	18	18	19	35	52	9.3	16.2	16	5	R47
	External jaw	132	40	41	51	93.5	7	8	5.08	5.08	18	18	19	35	52	9.3	16.2	16	5	R47
SC-16	Internal jaw	146	52	50	44	102	7	10.5	5.08	5.08	20	20	23	40	58	11.8	16.2	16	6	R53
	External jaw	146	43	50	53	102	7	10.5	5.08	5.08	20	20	23	40	58	11.8	16.2	16	6	R53

## ■ Hard Jaw (JN series)

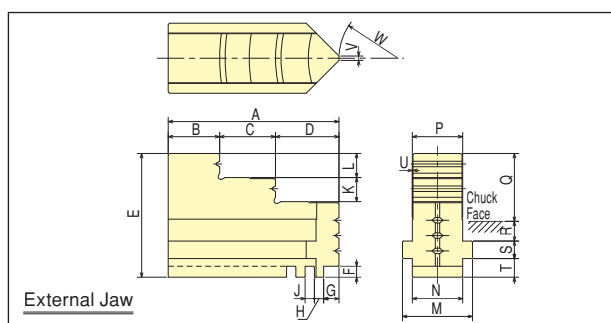
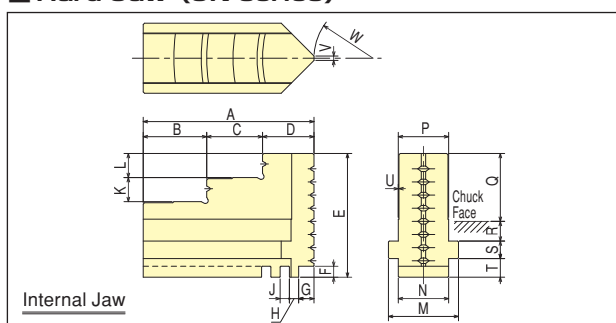

## ■ JN series Jaw Dimensions

Model		A	B	C	D	E	F	G	H	J	K	L	M	N	P	Q	R	S	T	U	V	W
JN06	Internal jaw	66	26.5	19	20.5	48.5	4.5	5.5	3.629	3.629	9	9	29	21	21	27	8	6.5	7	0.3	2	R19.5
	External jaw	66	18	19	29	48.5	4.5	5.5	3.629	3.629	9	9	29	21	21	27	8	6.5	7	0.3	2	R19.5
JN07	Internal jaw	78	29	25.5	23.5	56.5	5	7	4.233	4.233	11	11	32	23	23	31	9	8	8.5	0.3	2	R27
	External jaw	78	20.5	25.5	32	56.5	5	7	4.233	4.233	11	11	32	23	23	31	9	8	8.5	0.3	2	R27
JN09	Internal jaw	88	34	28	26	62.5	5	7.5	4.233	4.233	13	13	38	27	27	33	10.5	9.5	9.5	0.3	3	R34.5
	External jaw	88	24	28	36	62.5	5	7.5	4.233	4.233	13	13	38	27	27	33	10.5	9.5	9.5	0.3	3	R34.5
JN10	Internal jaw	98	36.5	32	29.5	66.5	5	7.5	4.233	4.233	14	14	38	27	27	37	10.5	9.5	9.5	0.3	3	R42
	External jaw	98	28	32	38	66.5	5	7.5	4.233	4.233	14	14	38	27	27	37	10.5	9.5	9.5	0.3	3	R42
JN12	Internal jaw	113	41.5	36.5	35	81	6	8	5.08	5.08	15	15	44	31	31	44	14.5	11	11	0.3	4	R42
	External jaw	113	33	36.5	43.5	81	6	8	5.08	5.08	15	15	44	31	31	44	14.5	11	11	0.3	4	R42

精造・NCS型  
 Jaws and Accessories

## ■ Gripping range

Model	Gripping range							
	External gripping					Internal gripping		
	A1	A2	A3	A4	Soft Jaw	B1	B2	Soft Jaw
SC-3(F)	2~35	33~55	53~70	2~35	(2~70)	24~44	42~64	(24~64)
SC-4(F)	3~43	41~69	67~95	3~43	(3~95)	29~57	55~84	(29~84)
SC-5(F)	3~46	44~77	75~110	3~46	(3~110)	33~67	65~100	(33~100)
JN06	3~64	62~112	110~160	3~64	-	48~100	98~150	-
JN06T	3~64	62~112	110~160	-	3~160	55~104	102~150	55~150
JN06R	3~64	62~112	110~160	-	-	55~104	102~150	-
JN07	4~72	70~126	124~180	4~72	-	56~114	112~170	-
JN07T	4~68	66~124	122~180	-	4~180	62~117	115~170	62~170
JN07R	4~68	66~124	122~180	-	-	62~117	115~170	-
JS07	4~72	70~126	124~180	4~72	-	56~114	112~170	-
JT07	-	-	-	-	4~180	-	-	62~170
JN08R	4~76	74~138	136~200	-	-	62~127	125~190	-
JN09	5~84	82~150	150~220	5~84	-	62~137	135~210	-
JN09T	5~80	78~150	148~220	-	5~220	70~141	139~210	70~210
JN09R	5~80	78~150	148~220	-	-	70~141	139~210	-
JS09	5~84	82~152	150~220	5~84	-	62~137	135~210	-
JT09	-	-	-	-	5~220	-	-	70~210
JN10	5~96	94~178	176~260	5~96	-	70~161	159~250	-
JN10T	5~94	92~177	176~260	-	5~260	80~166	164~250	80~250
JN10R	5~94	92~177	176~260	-	-	80~166	164~250	-
JN12	10~108	108~204	202~300	10~108	-	86~189	187~290	-
JN12T	10~108	108~204	202~300	-	10~300	90~191	189~290	90~290
JN12R	10~108	108~204	202~300	-	-	90~191	189~290	-
SC-14	25~118	116~210	208~315	25~118	-	107~188	186~290	-
SC-16	25~132	130~215	213~360	25~132	-	113~212	210~340	-

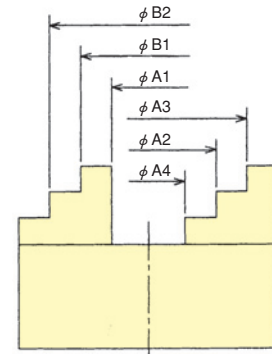

SC(F)/JN/JS type

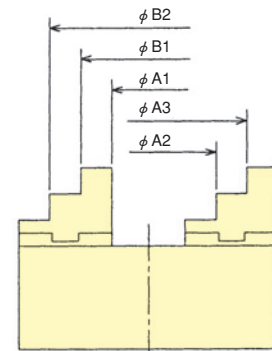

JN-T/JN-R type

## ■ Chuck handle Dimensions

Model	F1	F2	F3	F4	F5
SC-3	65	15	8	110	7
SC-4	70	17	8	140	8
SC-5	75	20	10	170	8
JN06	120	20	10	210	10
JN07	160	20	12	240	11
JN09	160	22	12	290	12
JN10	160	22	12	360	12
JN12	200	26	16	390	14
SC-14	140	30	16	450	15
SC-16	140	30	16	450	15
IC-4	75	12	8	120	6
IC-6	100	13	8	150	8
IC-8	130	15	10	200	10
IC-10	150	18	12	250	10
IC-12	170	19	12	300	12
IC-14	170	19	12	300	12
IC-16	220	22	16	400	14
IC-18	220	22	16	400	14

