

6-M5 ネジ深10
6-M5 DEPTH 10

SPECIFICATIONS 仕様	
PISTON DIA シリンダ内径	95 mm
PISTON STROKE ピストンストローク	12 mm
PISTON THRUST ピストン推力	22.0 kN (2243 kgf)
OIL PRESS. 油圧	4.0 MPa (40.8 kgf/cm ²)
MAX OPERATING PRESSURE 最高油圧力	4.0 MPa (40.8 kgf/cm ²)
MAX. SPEED 最高回転数	8000 min ⁻¹
MASS 質量	8.5 kg
MOMENT OF INERTIA 慣性モーメント	0.008 kg·m ²
OIL LEAKAGE 漏油量	3.0 l/min (ISO. V0 32.50°C. 3.0MPa)

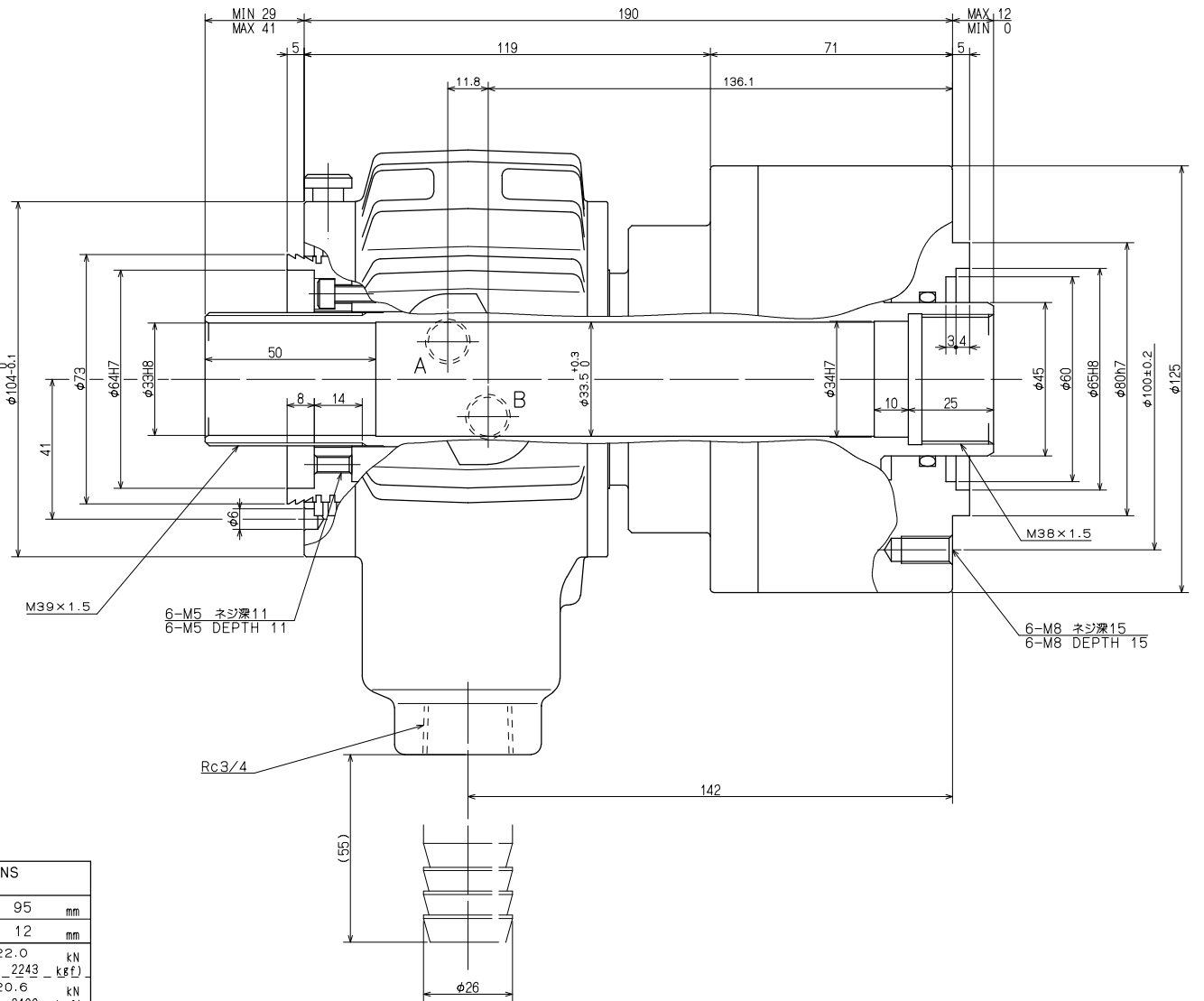

6-M5 ネジ深11
6-M5 DEPTH 11

6-M8 ネジ深15
6-M8 DEPTH 15

CAREER	SCALE	TYPE	F0933H	WEIGHT	kg
MANAGER	CHIEF	DRAWN BY	NAME	F0933H カイウェイ F0933H OUTSIDE VIEW	
KITAGAWA IRON WORKS CO., LTD.			DATE	DRW NO.	61R229220 4