

仕様 SPECIFICATIONS	
削出精度 MACHINING ACCURACY	20 sec/φR
再現精度 REPEATABILITY	4 sec/φR
テーブル最高回転速度 MAXIMUM ROTATION SPEED	16.6 min ⁻¹ [モータ 2000 min ⁻¹]
クランプトルク CLAMPING TORQUE	駆力 4000N・m [圧力 3.5MPa]
許容最大油圧力 MAXIMUM HO. PRESS	3.5 MPa
許容積載質量 ALLOWABLE MASS OF WORK	ΔVERT 250 kg
許容積載ワーク径 ALLOWABLE WORK DIA.	φ430 mm
総減速比 TOTAL REDUCTION RATIO	1/120
取出質量 MASS OF ROTARY TABLE	276 kg
慣性モーメント MACHINE INERTIA (REVOLVED TO WORK SHFT)	0.002462 kgm ²

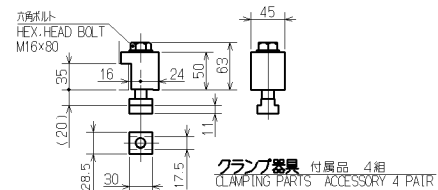
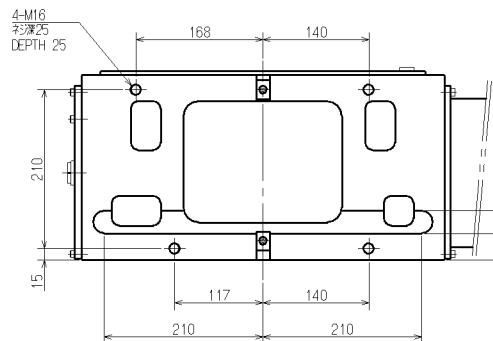
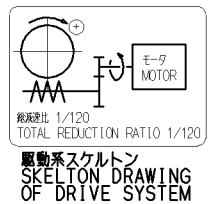
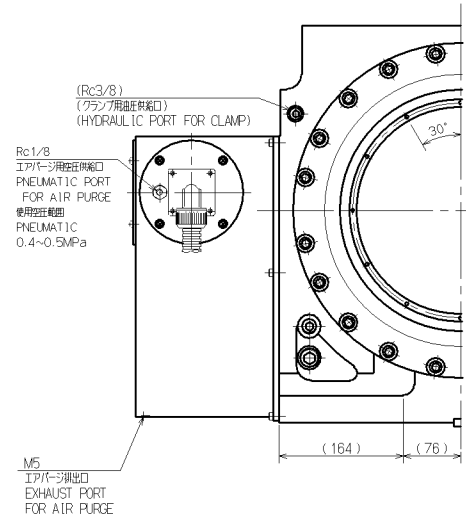
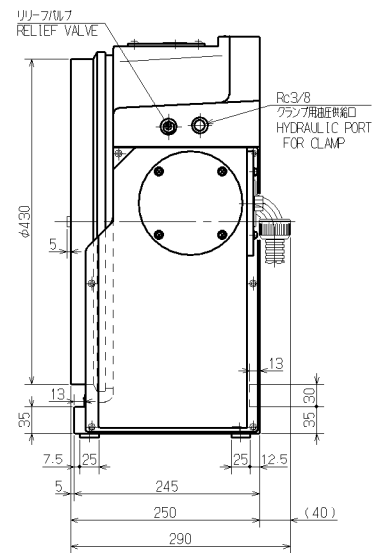
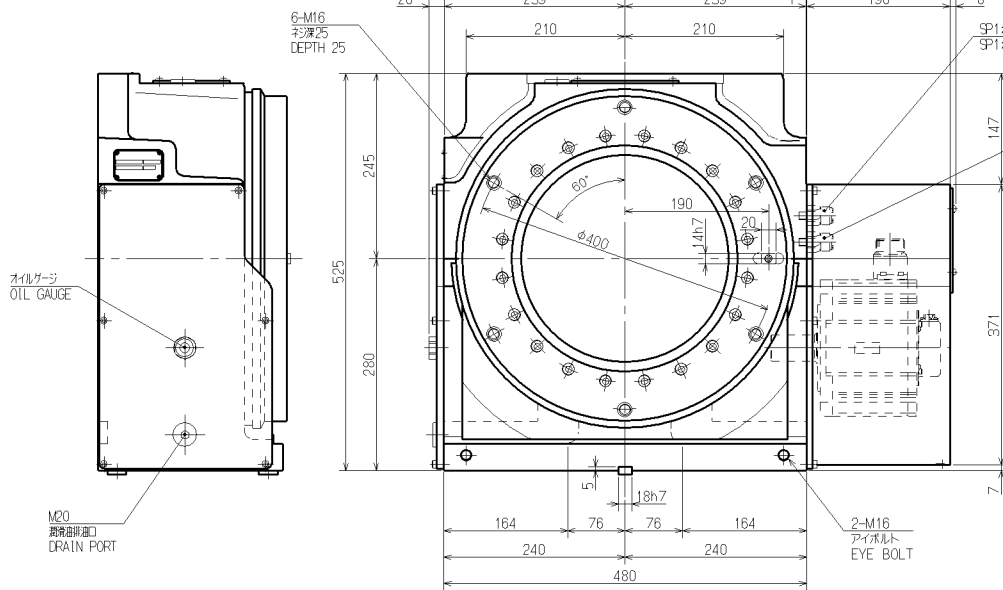
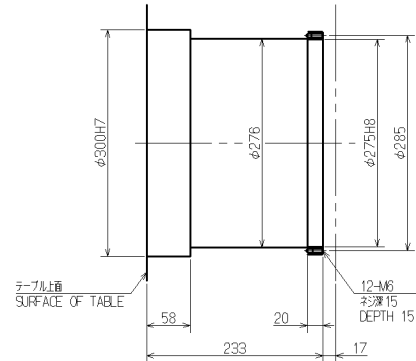
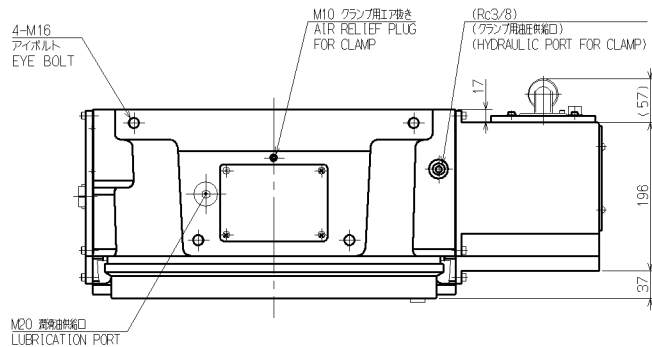

CAREER	SCALE	TYPE	TP430RHV00	WEIGHT	kg
W.D.	1:5	NCテーブル NC ROTARY TABLE			
MANAGER	CHIEF	DRAWN BY	NAME	TP430RHV00 ガイガイ OUTSIDE VIEW	
DATE			3RD ANGLE	DRW NO.	61E 28 1791 0
KITAGAWA IRON WORKS CO.,LTD.					