

仕様 SPECIFICATIONS			
引出精度 INDEXING ACCURACY	20 sec以内	許容稼働質量 ALLOWABLE MASS OF WORK	機軸径 200 k <sub>g</sub> 立軸径 100 k <sub>g</sub>
再現精度 REPEATABILITY	4 sec以内	許容積載ワーク径 ALLOWABLE WORK DIA.	φ200 mm
テーブル最高回転速度 MAXIMUM ROTATION SPEED	41.6 min <sup>-1</sup> [モータ 3000 min <sup>-1</sup> ]	総減速比 TOTAL REDUCTION RATIO	1/72
クランプトルク CLAMPING TORQUE	820N·m [PNEUMATIC 0.5MPa]	製品質量 MASS OF ROTARY TABLE	64 k <sub>g</sub>
許容最大空圧力 MAXIMUM PNEUMATIC PRESS	0.6 MPa	最低モーメント慣性 MINIMUM MOMENT OF INERTIA (BASED TO MOTOR SHAFT)	0.00014kgm <sup>2</sup>

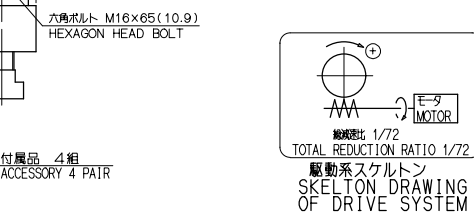
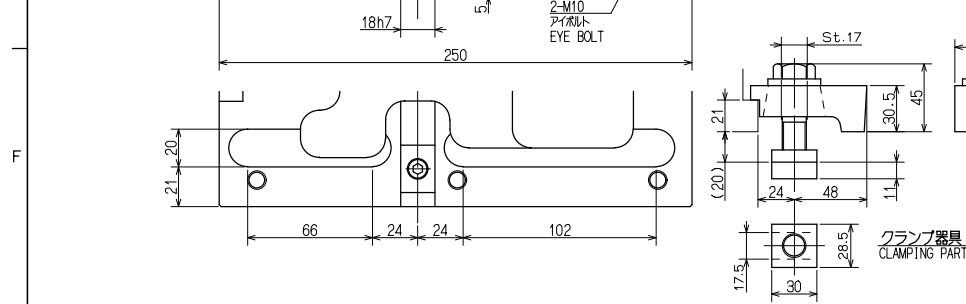
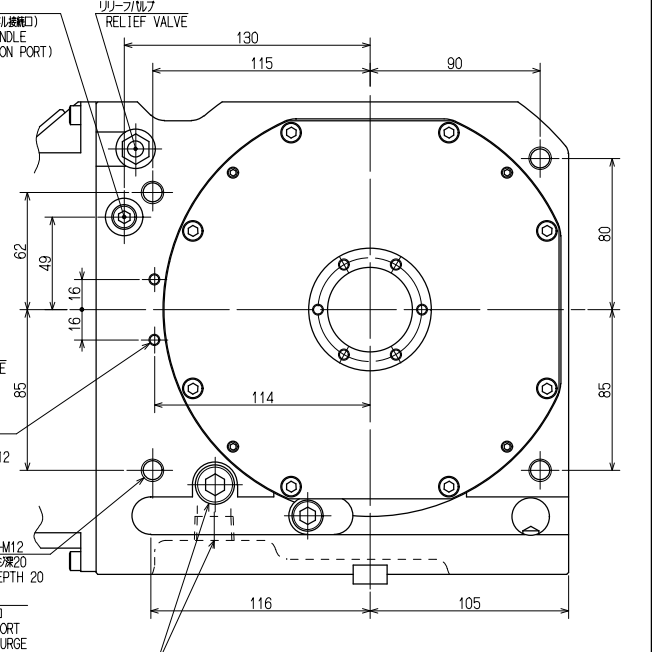
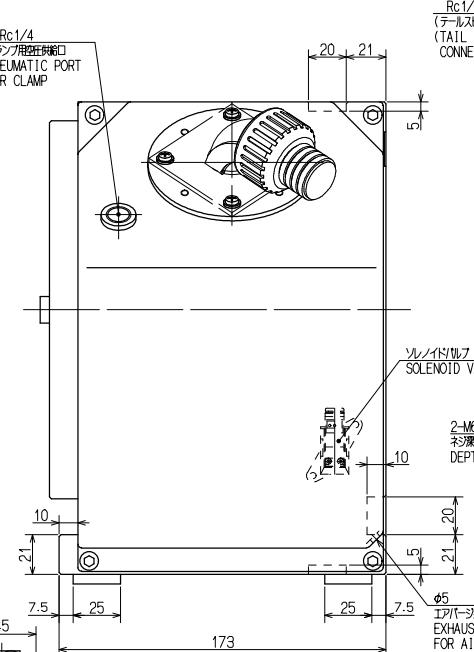
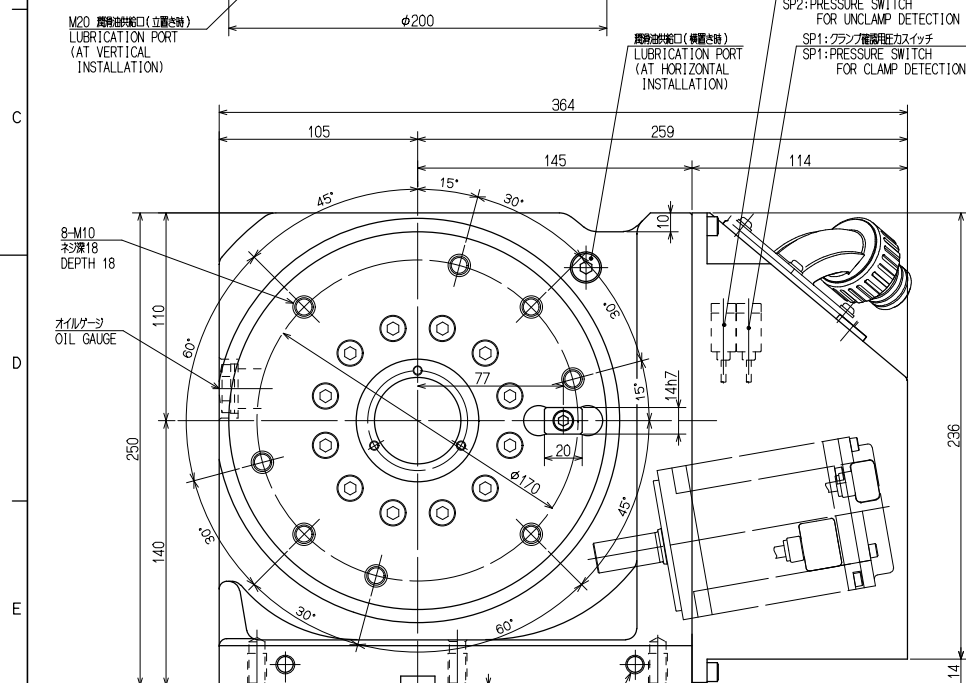

CAREER	SCALE	TYPE	GT200RAV00	WEIGHT	k <sub>g</sub>
W.D.	1:2	NAME	NCテーブル NC ROTARY TABLE		
MANAGER	CHIEF	DRAWN BY	GT200RAV00	ガイケイ OUTSIDE VIEW	
KITAGAWA IRON WORKS CO.,LTD.		DATE	DRW NO.	61E271433	1/1