

クランプ部詳細(10か所)  
DETAIL OF CLAMP HOLE  
(10 PLACES)  
(1 : 2)

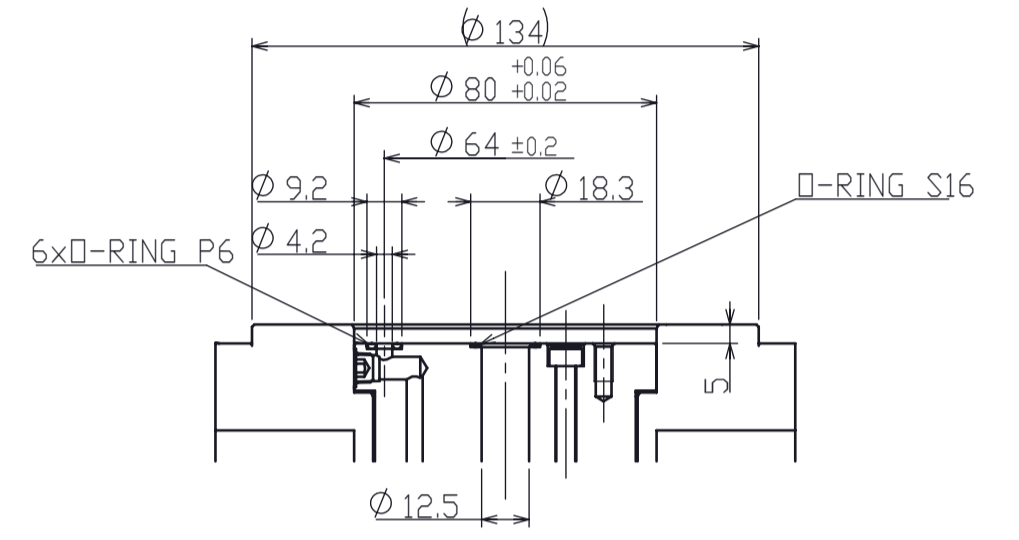

テーブル面詳細  
DETAIL OF TABLE  
(1:2)

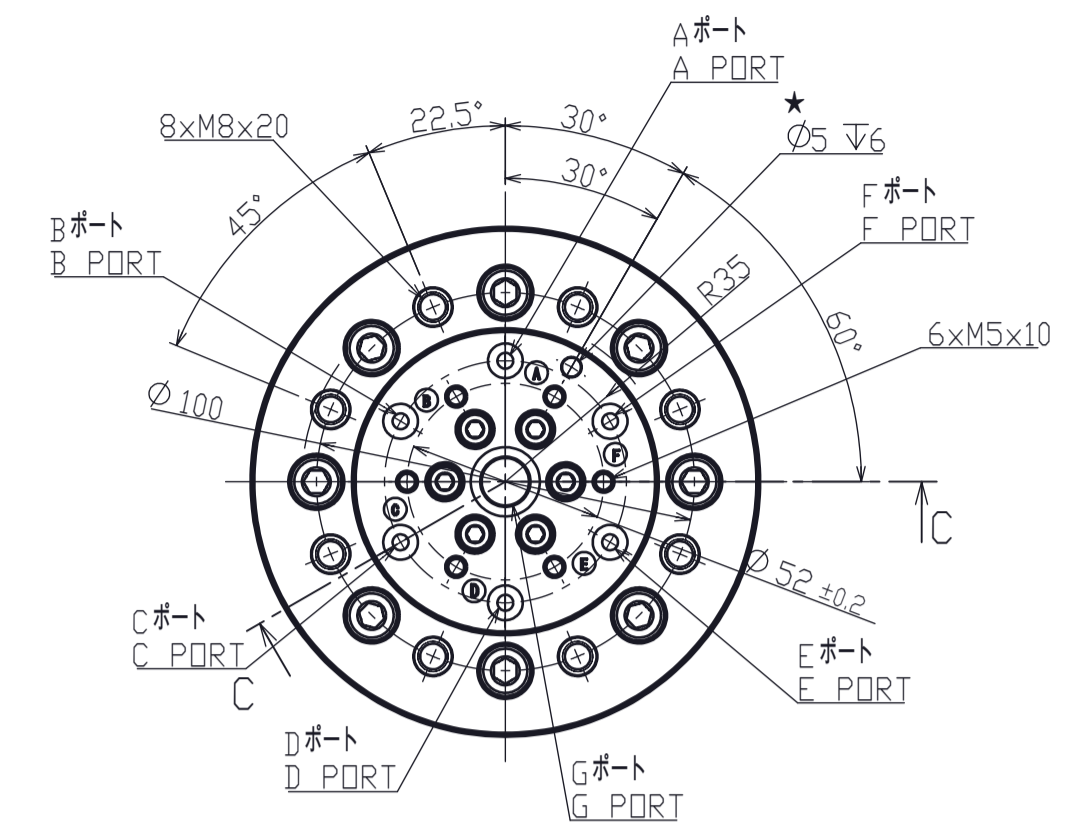
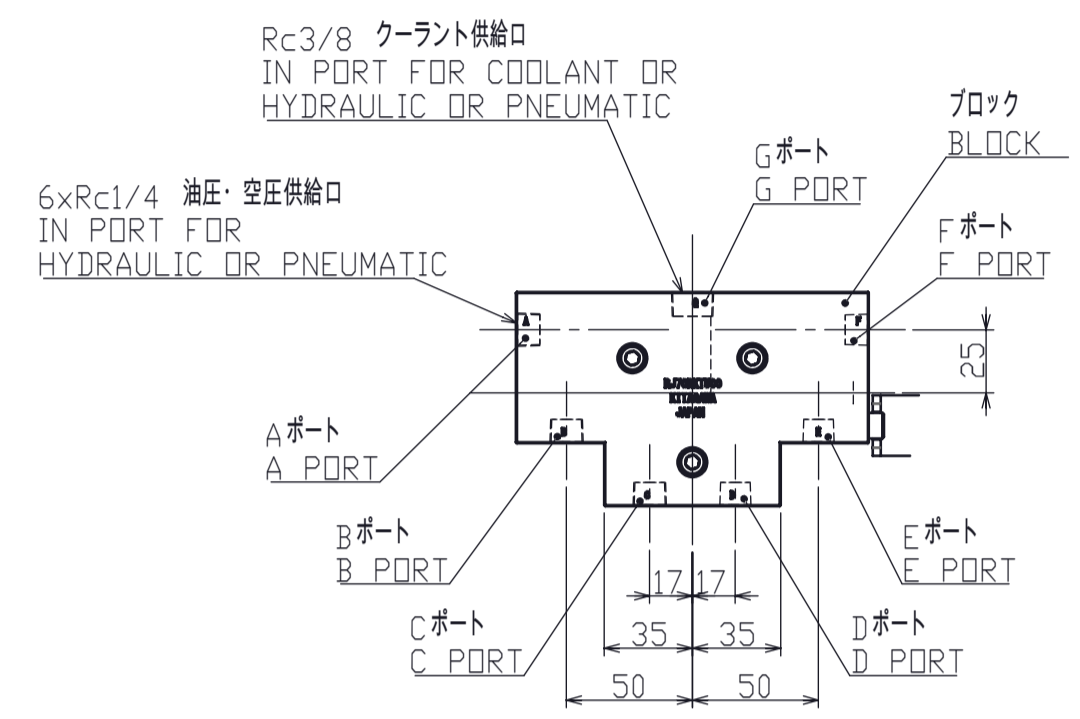

シグ用配管接続位置詳細 (1 : 3)

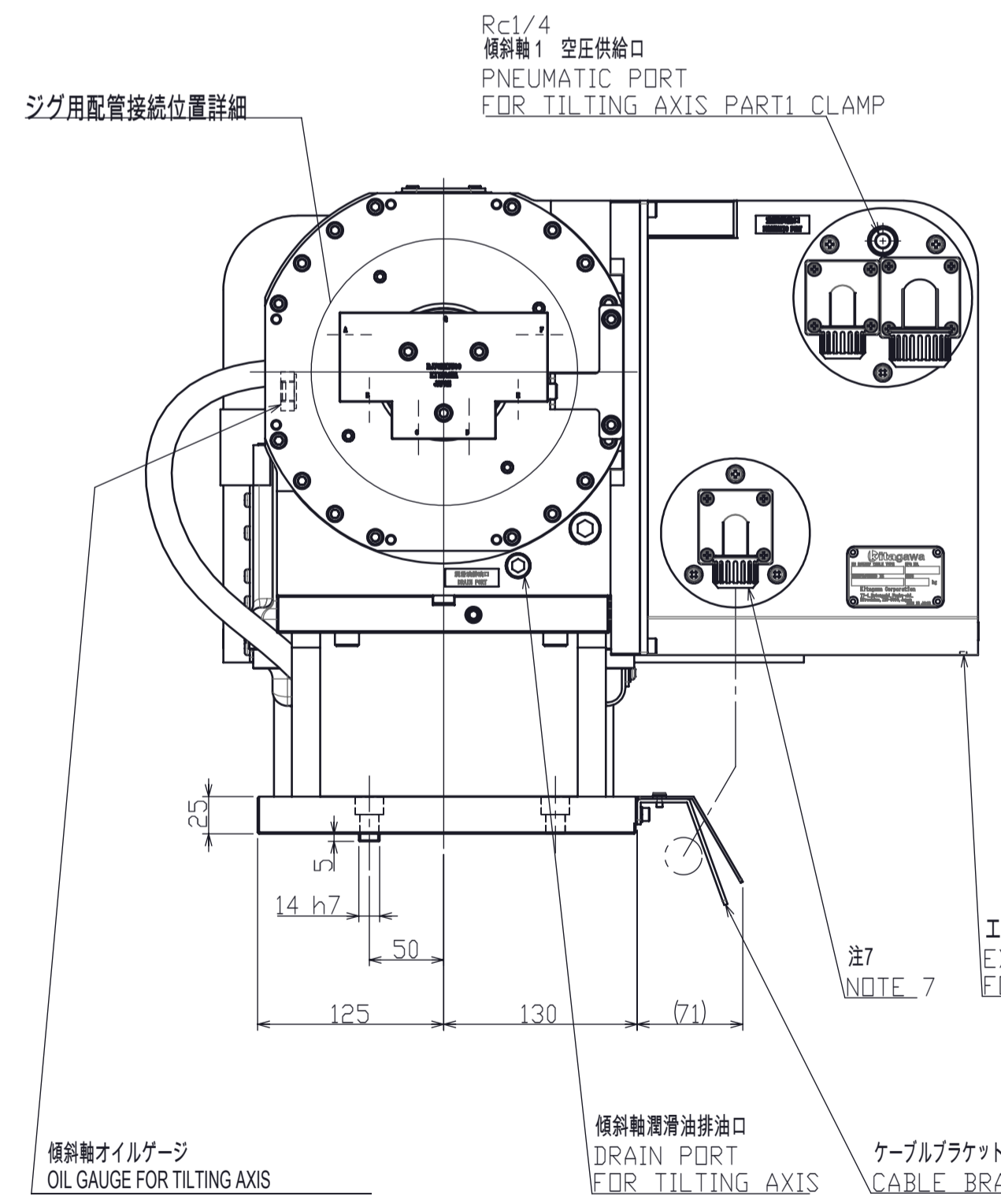
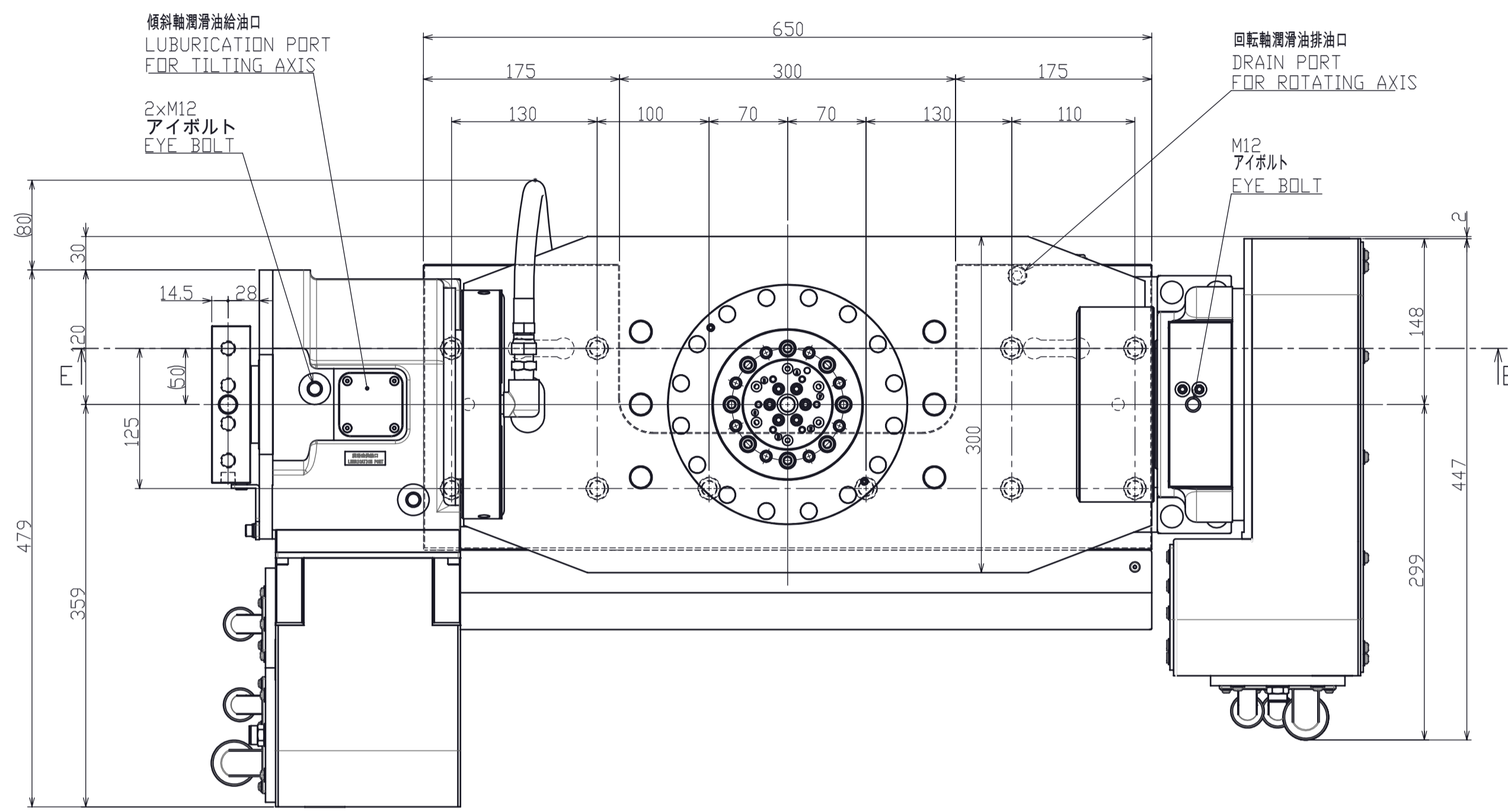

シグ用配管接続位置詳細 (1:3)

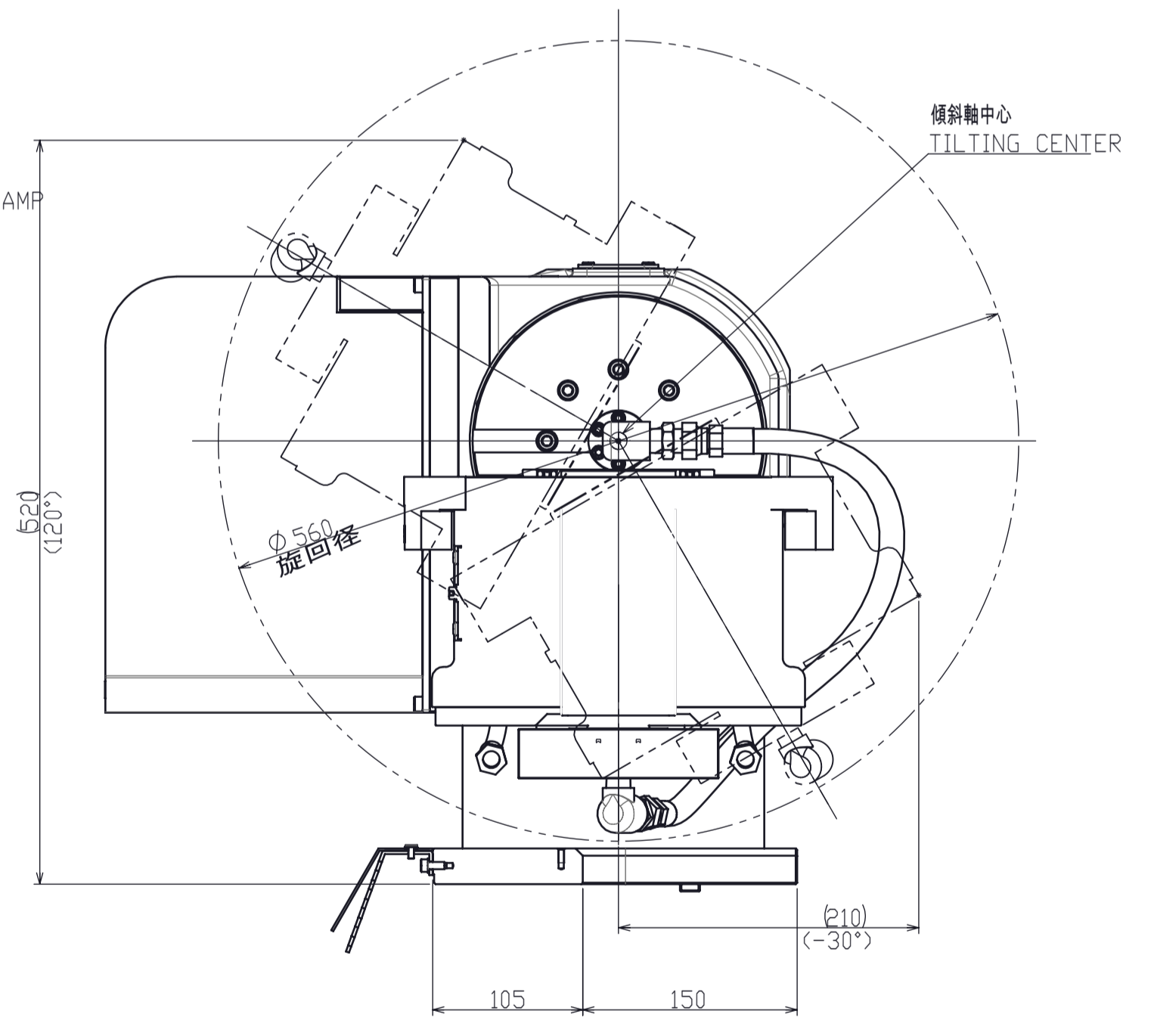
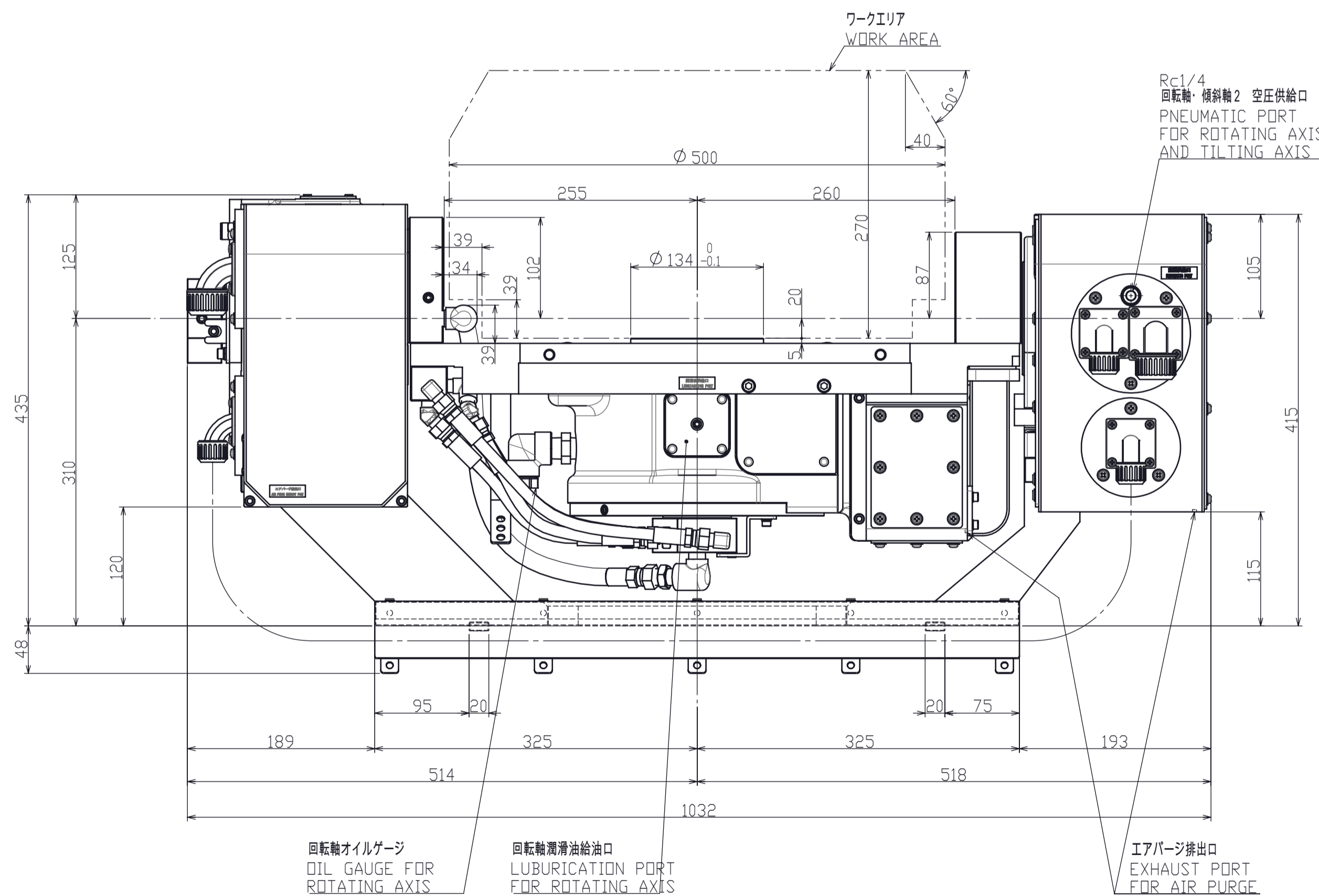

CAREER		SCALE	TYPE	RKT500FFR
APPROVAL	INSPECTION	1:4	NAME	NC ROTARY TABLE
	DRW 3D	3RD ANGLE	NAME	RKT500FFR OUTSIDE VIEW ガイキ
Kitagawa Corporation	DATE		DRW NO.	61E118166 0 1/1 P