

仕様 SPECIFICATIONS			
割出精度 INDEXING ACCURACY	20 sec以内	許容積載質量 ALLOWABLE MASS OF WORK	横 HORIZ 160 kg 立 VERT 80 kg
再現精度 REPEATABILITY	4 sec以内	許容積載ワーク径 ALLOWABLE WORK DIA.	φ165 mm
テーブル最高回転速度 MAXIMUM ROTATION SPEED	41.6 min <sup>-1</sup> [モータ MOTOR 3000 min <sup>-1</sup> ]	総減速比 TOTAL REDUCTION RATIO	1/72
クランプトルク CLAMPING TORQUE	電圧 [VOLTAGE] 340N·m 圧力 [PRESSURE] 0.5MPa	総質量 MASS OF ROTARY TABLE	42 kg
許容最大空圧力 MAXIMUM PNEUMATIC PRESS	0.7 MPa	回転モーメントイナーシャ (REDUCED TO MOTOR SHAFT) MACHINE INERTIA	0.00009kg·m <sup>2</sup>

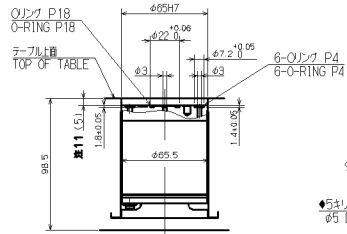

ロータリジョイントの取り付け詳細  
ROTARY JOINT ATTACHMENT SIDE DETAILS

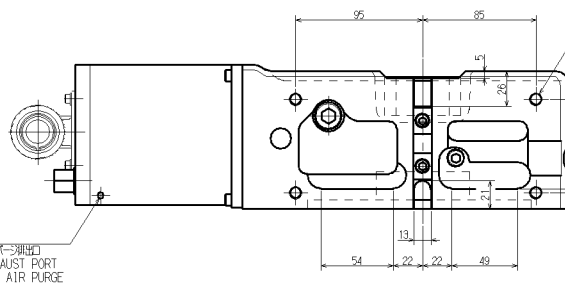
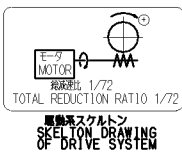
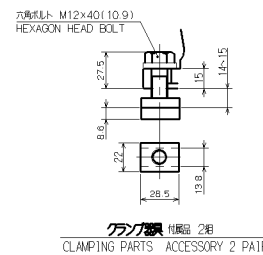
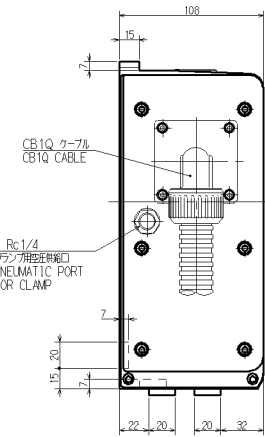
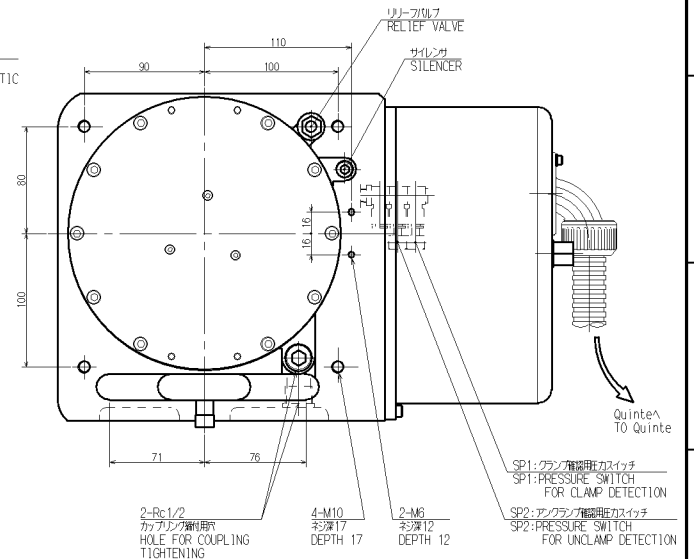
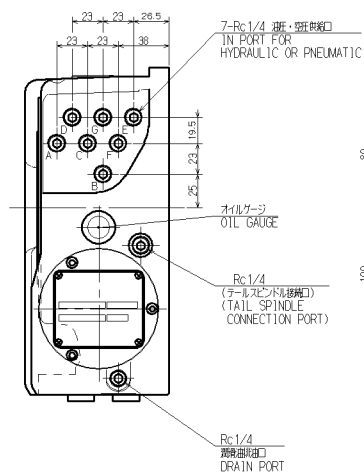
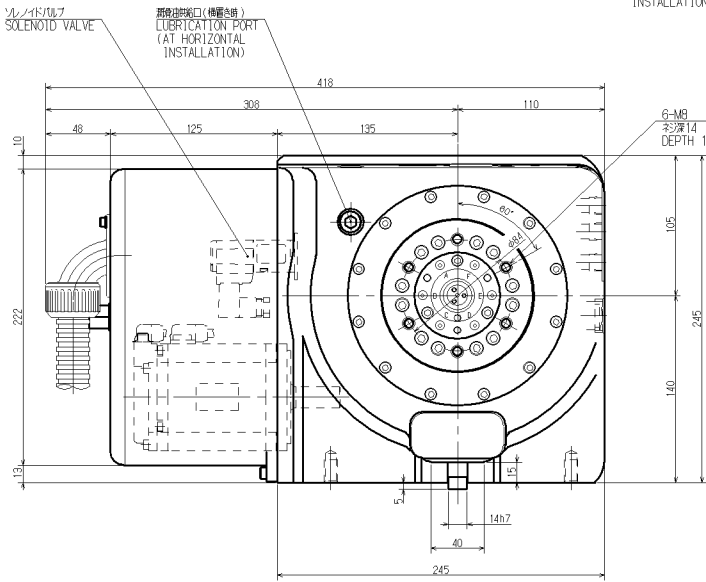
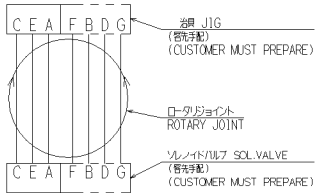
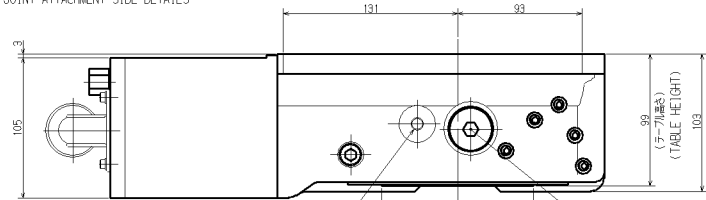

CAREER		SCALE	TYPE	CKR160LV00	WEIGHT	kg
W. D.		1:2	NCテーブル NC ROTARY TABLE			
MANAGER	CHIEF	DRAWN BY	NAME	CKR160LV00 ガイケイ OUTSIDE VIEW		
KITAGAWA IRON WORKS CO.,LTD		DATE	3RD ANGLE	DRW NO.	61E 11 3807 0	