



**ROTARY
CYLINDER**

中実回転エアシリンダ

High-Speed Air Cylinder with Non-Through-Hole

AY-R series

歪み易い薄肉ワークに最適

Ideally for extremely thin walled work-pieces

●低推力でも確実な動作!

Secure operation even at low thrust

歪みやすい薄肉ワーク加工に最適なエアシリンダ

Air cylinder for machining easily deformed thin work-pieces



■ 寸法図 Dimensional Drawings

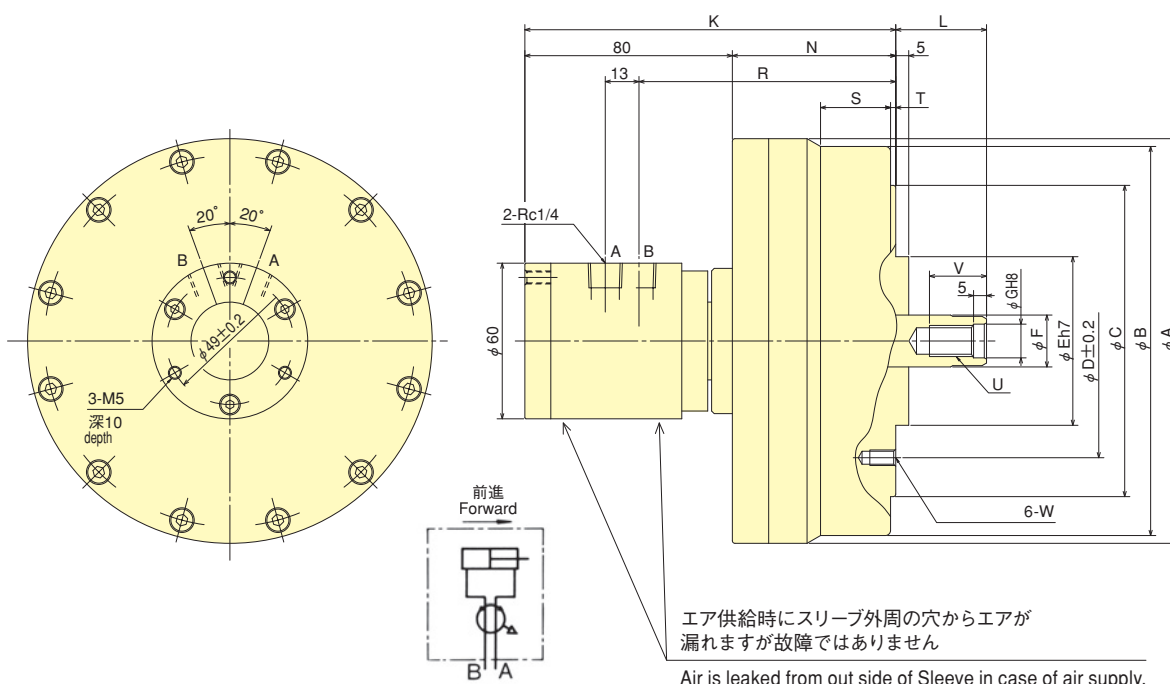

■ 寸法表 Dimensions

型式 Model	A	B	C	D	E (h7)	F	G (H8)	K	L max.	L min.	N	R	S	T	U	V	W 深さ depth
AY1315R	156	150	120	90	65	20	13	143	35	20	63	99	27	2	M12	22	M 6×11
AY1720R	200	195	140	100	80	25	17	162	65	45	82	118	45	5	M16	30	M10×16
AY2225R	255	245	170	130	110	30	21	173	71	46	93	129	33	5	M20	35	M12×20

■ 仕様表 Specifications

※ピストン推力：エア圧0.5MPa【効率75%時】

※Piston thrust : air pressure 0.5MPa[at efficiency 75%]

型式 Model	ピストンストローク Piston stroke mm	ピストン表面積 Piston Area cm ²	ピストン推力 Piston thrust kN	最高使用エア圧力 Max operation pressure MPa	許容最高回転速度 Max. Speed min ⁻¹	質量 Net Weight kg	慣性モーメント Moment of inertia kg·m ²
AY1315R	15	131	4.9	0.8	5000	5.0	0.010
AY1720R	20	227	8.5	0.8	5000	8.2	0.028
AY2225R	25	378	14.1	0.8	4000	9.8	0.080

回転
Cylinder