

**WORK GRIPPER****ワークグリッパ****AS series**

ステーションリチャックのKITAGAWAスタンダードタイプ M/C関係のワークホールディングもKITAGAWA

- エアシリンダを内蔵した薄型・軽量設計
- エア配管だけで取付け簡単
- バーワークやエアブローに最適の中空構造
- 当社パワーチャックとのソフトジョー共用可能
- オプションのロックバルブユニット使用により、配管を外して加工可能

*ロックバルブユニット使用時はCE対応品

※配管回路にルブリケータを設けてください。



■ 寸法図

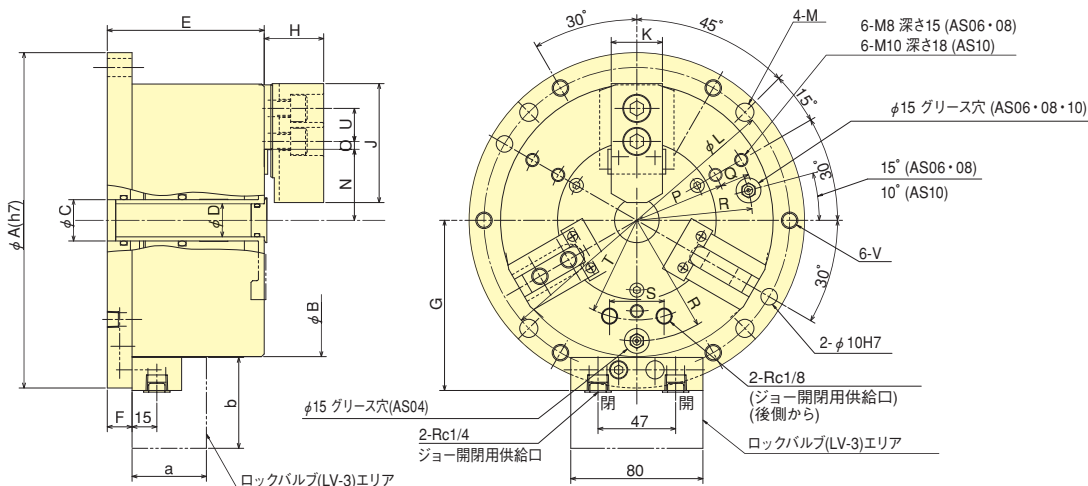

■ 寸法表 ※a, bの寸法はLV-3(ロックバルブ)の寸法

型式	寸法	ϕA (h7)	ϕB	ϕC (H7)	ϕD	E	F	G	H	J	K	ϕL (± 0.2)	ϕM	N max.	N min.	O max.	O min.	P	Q	R
AS04		148	110	20	-	90	15	75.5	27	55	23	130	9	25.5	22.9	9.75	6.75	-	-	43
AS06		203	165	25	20	95	15	103	36	72	31	185	11	44.5	41.9	9.25	4.75	55	18	70
AS08		248	210	36	30	106	15	125.5	42	95	35	230	11	53	49.85	14.75	8.75	68	25	90
AS10		300	254	50	43	110	16	147.5	46	110	40	280	13	66	62.85	16	8.5	85	30	110

型式	寸法	S	T	U	V	a	b
AS04		33	34	14	M8	45	55
AS06		33	60.3	20	M10	45	55
AS08		33	80	25	M10	45	55
AS10		33	95	30	M12	45	55

※空気消費量はプランジャストローク10mm当り、圧力0.6MPa時

■ 仕様表 ※把握径/把握範囲は標準のソフトジョーを使用した場合。

型式	仕様	ジョーストローク (直径) mm	把握力 [エア圧力0.6MPa (0.6kgf/cm ²) kN]	質量 kg	許容最大エア圧力 MPa	適用ソフトジョー	把握径 mm		空気消費量 (N _d)
							Max.	Min.	
AS04		5.2	7.5	7.3	0.7	SJ04B1	110	8	0.40
AS06		5.2	21.0	16.0	0.7	SJ06B1	165	26	1.04
AS08		6.3	33.0	27.7	0.7	SJ08B1	210	38	1.81
AS10		6.3	48.0	42.5	0.7	SJ10A1	254	53	2.52



WORK GRIPPER

Work Gripper

AS series

Pneumatically operated stationary chuck Can be used as an alternative to a fixture

- Small and lightweight design, with inbuilt air cylinder
- Easy mounting by air piping
- Hollow structure optimal for bar work-piece and air blow
- Standard Soft Jaw for Power Chuck is used
- By using the optional lock valve unit, it is possible to remove the piping during machining

*CE compliant when lock valve is used

※Provide a lubricator in the piping circuit.



Dimensional Drawings

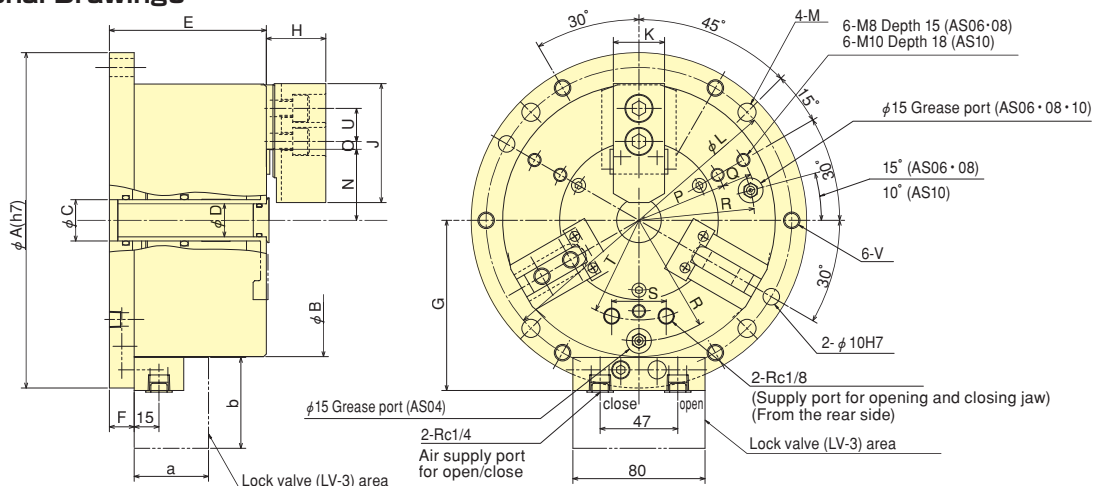

Dimensions

※The dimensions of a/b marked are the size of LV-3(Lock-valve).

Model	Dimensions	ϕA (h7)	ϕB	ϕC (H7)	ϕD	E	F	G	H	J	K	ϕL (± 0.2)	ϕM	N max.	N min.	O max.	O min.	P	Q	R
AS04		148	110	20	—	90	15	75.5	27	55	23	130	9	25.5	22.9	9.75	6.75	—	—	43
AS06		203	165	25	20	95	15	103	36	72	31	185	11	44.5	41.9	9.25	4.75	55	18	70
AS08		248	210	36	30	106	15	125.5	42	95	35	230	11	53	49.85	14.75	8.75	68	25	90
AS10		300	254	50	43	110	16	147.5	46	110	40	280	13	66	62.85	16	8.5	85	30	110

Model	Dimensions	S	T	U	V	a	b
AS04		33	34	14	M8	45	55
AS06		33	60.3	20	M10	45	55
AS08		33	80	25	M10	45	55
AS10		33	95	30	M12	45	55

※Air Consumption = Under Pressure 0.6MPa Plunger Stroke per 10mm

※Gripping dia./gripping range is with standard soft jaws.

Specifications

Model	Specifications	Jaw Stroke (diameter) mm	Gripping Force [Pneumatic at 0.6MPa (0.6kgf/cm ²)] kN	Net Weight kg	Max. air pressure MPa	Matching Soft top jaw	Gripping range mm		Air consumption (N _l)
							Max.	Min.	
AS04		5.2	7.5	7.3	0.7	SJ04B1	110	8	0.40
AS06		5.2	21.0	16.0	0.7	SJ06B1	165	26	1.04
AS08		6.3	33.0	27.7	0.7	SJ08B1	210	38	1.81
AS10		6.3	48.0	42.5	0.7	SJ10A1	254	53	2.52